

HOME WING



Newsletter of the Home Wing of Van's Air Force — Builders and Fliers of Van's RV Series Aircraft

Brian's New Look



My RV 6A has been flying for more than 2 ½ years and now that my hangar mate's (Kevin Lane's) RV is painted and tricked out, I decided I needed to re-double my efforts to get it into the paint shop. Polished metal is great – but how do you polish Bondo?

Picking the colors and scheme was the easy part. Getting all the surfaces ready was another story. The area in front of my canopy was particularly ugly. Kevin and I spent about a half day on it and then I worked on it more until it was better. I applied epoxy and 'glass to the trailing edge of the tilt-up portion of the canopy so it would overlap the rear fixed portion. I found a lot of wind noise in flight came from this area. I had to do it twice because the first one peeled off with little force. I

bought two quarts of Acrylic urethane sandable primer which I found to be hard to spray without a big compressor and a lot of pressure (neither of which I had). Also, the cowling splits at the front never fit well so I worked on that area until I was happier.

I had visited with Craig Roberts in Aurora and Steve Smith at Custom Aircraft Painting in Longview as well as two other paint shops – one in Idaho and in Topeka, Kansas (I was planning a business trip near there). I ended up choosing Steve Smith who also painted Kevin's RV 6A, John Roberts' RV 4, and several other RV's as well. I decided to use DuPont's Chromabase with two coats of Clear.

(Continued on page 3)



Meeting coordinator:
Randall Henderson
503-297-5045
randallh@home.com

MONTHLY MEETING:

(2nd Thursday every month, various locations, 7:00 pm)

Place: Dean Psiropoulos' house
153 NE 41st Avenue
Hillsboro, OR
Date: Thursday September 14, 2000
Time: 7:00 pm
Phone: 503-681-0183

The September meeting will be at Dean Psiropoulos' house in Hillsboro. Dean is building an RV-6A "slow-build" kit (for the last 3.5 years) and is in the pre-jigging stages of the fuselage

DRIVING DIRECTIONS:

From Portland and points east:

Take Hwy 26 west to the Cornelius Pass exit, go right off the exit onto Cornelius Pass road 1.2 miles to Cornell Road, take a right on Cornell Road and go 1.2 miles to Elam Young Parkway, left onto Elam Young Parkway about one half mile to 53rd, left on 53rd to Baseline Road, right onto Baseline Road and down to 41st Ave, right on 41st, down to the 5th duplex on the left (153 NE 41st).



From Hillsboro airport: Just take Cornell Road east to Elam Young Parkway and follow the rest of the directions above. Home phone is 503-681-0183 in case anyone gets lost.

Tentative future meeting schedule:

Oct: Steve Householder's hangar at HIO (tentative)
Nov: Robin Wessel's house
Dec: Jeff Jasinsky's house (tentative)

Meeting places are always needed; if you'd be interested in hosting a meeting please contact Randall Henderson at 503-297-5045 or randallh@home.com

EAA CHAPTER 105 Pancake Breakfast:
First Saturday of every month at Twin Oaks Airpark, 8:00 am, \$5.00 (always lot's of RVs to look at too!)
This month: 9/2/2000

EAA CHAPTER 105 Monthly Meeting:
Third Thursday of every month at the EAA 105 hangar/clubhouse, Twin Oaks Airpark, 7:00 pm
This month: 9/21/2000

EAA CHAPTER 902 Monthly Meeting:
Second Wednesday of every month at the Mulino Airport in the OPA building. For info call Gary Sparks at 503-251-0843
This month: 9/13/2000

Homecoming 2000

PLEASE HELP US SPREAD THE WORD
Due to the confluence of Oshkosh, our move to our new factory, the acquisition of new equipment and a host of other factors, our RVator newsletter is behind schedule this year and may not reach some subscribers before the Homecoming. Please let any potentially interested neighbor or acquaintance know about the Homecoming dates and information here on Van's Website. Give them the address, heck, print it out and leave in under their windshield wiper...whatever. We appreciate the help.

Van's traditional Homecoming Fly-in will be held Sept. 2-4, 2000 at Van' new home on the Aurora OR airport. Since we have not yet occupied the site, many details of parking, etc are still uncertain, but here is some information that may help your planning. The banquet will move from Sunday to Saturday night. It will be held at the Holiday Inn in nearby Wilsonville. The address is 25425 SW 95th Avenue, Wilsonville, OR, phone 503-682-2211, fax 503-582-5596. This is essentially alongside the I-5 freeway at Exit 286. The Holiday Inn also has a block of 20 rooms available (until Aug. 19) for Van's at \$75.00 per night, single or double occupancy, king size bed or 2 doubles

Banquet tickets may be purchased from Van's in advance by phone, fax or e-mail and picked up at the factory or at the door. Buffet style, menu and price to be determined but plan on about \$24 per person. Tickets available starting Aug. 1, orders must be received at Van's by Aug. 19. The airfield barbecue will be held Sunday night at Van's new factory and hangar. Tickets available (price to be determined, but in the \$12.00 range) from Van's starting Aug 1.



(Continued from page 1)

On March 9th, I flew it to Longview and removed all the control surfaces, the wing root fairings, all the fiberglass parts, and the canopy. That day worked out well as I was leaving for a 2 ½ week long business trip the next day.

When I got back, nothing had been done. Steve had spent a week in Las Vegas painting new registration numbers on a 727 (\$13,000). The following Saturday, Jim Franich and I used more Bondo and sanded a lot of the fiberglass parts. Another couple of days were spent preparing the screw heads (which I got all mixed up), laying out the paint lines, etc.

Finally after about 5 ½ weeks, it was done. I came back up to put it together and discovered there were a few areas which still needed work. I proceeded to put it back together (it took portions of three days - April 19, 20, & 21). My name had not been painted on the canopy (the stencil was too big), a repaired spot on the left elevator came out poor, and there were a few spots of damage I had caused in the still-soft paint during reassembly. Also, the rear spar of the vertical stabilizer had some over-spray on it (Steve didn't realize it would be visible when the rudder was installed).

I flew it home on April 21st. It looked great except for the areas still needing work. I brought it back to Longview the following Friday (the day a tornado was suspected to have hit the town of St. Helens). McMinnville FSS had told me VFR was not recommended. I flew through two light rain showers with ceilings everywhere else between 1800 and 2200 and visibility always about 10 miles (I figured it was ok for a 20 min. trip from Troutdale).

On Sunday night (at 7:00 PM) I picked my RV up. I still need to remove the rudder to take care of the over-spray problem and pick up the leftover paint. Steve said he would paint that area if I brought it back and removed and replaced the rudder. All together, I spent a little less than \$1,000 total including materials for the painting. I do not know how much weight the paint added since I had made other modifications all of which increased the weight. I'm very happy with the way it tuned out. I was getting a little embarrassed with the way it looked – especially when there are so many other RV's with their cool paint jobs.

...Brian

Flush Riveting Strength

Editors note: I subscribe to a GlaStar mailing list just out of curiosity. Recently a GlaStar builder posted the following message on some testing he did on the relative strength of panels joined by flush-riveting versus universal rivets. We all know that dimpled panels with flush rivets are stronger, but I thought you might find this testing data interesting verification.

Subject: flush riveting wings, some test results
 From: thompson_foundry@telus.net
 Date: Mon, 14 Aug 2000 09:09:38 -0700

I have been trying to decide if my Glastar wings should be flush riveted or not. All of the information that I have seen so far indicated that flush riveting might be ok. Since I am now at the stage where I am dimpling the wing skins, its now or never to make a decision. I decided to make some test samples, just to see for myself what the differences are. What I wanted to see was the difference in tensile strength between counter sunk head (dimpled) and regular riveting.

I made up 24 tensile test samples using 0.020 and 0.032 alcad. The test strips were 3" long and 1" wide. I then riveted the samples with 3/32 and 1/8 rivets, with a 1/2" edge margin. The sample strips were cut on a bandsaw, and deburred with a belt sander, not pretty, but they were fairly consistent.

All of the rivets were squeezed, using standard dimensions of 1 1/2 diameter for the tail, and expecting 1/2" diameter for the height and 1 1/2 the diameter for the shop head. In the end I had four sets of comparisons to make, with three tensile strips for each type of rivet and sheet thickness.

- 0.032 sheet with 3/32 rivet
- 0.020 sheet with 3/32 rivet
- 0.032 sheet with 1/8 rivet
- 0.020 sheet with 1/8 rivet

Since I don't have easy access to a tensile testing machine, the following test setup was used: Hydraulic floor jack, modified to pull the tensile strips. The tensile strips had a 1/4" hole drilled at each end, and were bolted to the side of the jack. A small scale was used to measure the pressure on the handle of the jack. The numbers are MEANINGLESS, and must only be compared in groups. I had to change the length of the jack handle for each of the groups, to compensate for the limited size of the scale (the scale used would only register up to 72 ounces). I tried to be as consistent as possible with sam-

ple preparation, and testing, and the results were fairly consistent with each rivet type.

Group 1: 0.032 sheet, 3/32 rivet
 Counter sunk head: average pull 66 ounces stem pulled out of factory head Regular head: average pull 42 ounces clean rivet shear, minimal sheet distortion

Group 2: 0.020 sheet, 3/32 rivet
 Counter sunk head: average pull 80 ounces factory pulled through sheet Regular head: average pull 60 ounces sheet failed, shop head pulled through

Group 3: 0.032 sheet, 1/8 rivet
 Counter sunk head: average pull 86 ounces factory head pulled through Regular head average pull 74 ounces rivet sheared

Group 4 0.020 sheet, 1/8 rivet
 Counter sunk head: average pull 30 ounces sheet failed, shop head pulled through Regular head: average pull 0 ounces sheet failed, shop head pulled through

The weight of the jack handle (with extensions) was enough to cause failure in the 0.020 sheet with regular 1/8" rivets.

Conclusions: This was a very simple test, and the results may be meaningless in a real aircraft wing. In each case, the dimpled riveting system gave higher tensile test results. However, in a real aircraft wing, you would never see loads going this high, as the tensile strength was were the joint actually failed. Generally what happened was that the rivet started to tip over, with either the shop or factory head cutting into the sheet, finally causing the sheet to tear. Once the rivet starts to tip over, the loads on the joint start being more tensile than in shear.

In the case of the 0.032 sheet and 3/32 rivets, the difference in joint failure was quite significant. With regular rivets, the entire tensile load was being taken by the shank of the rivet. When the rivet failed, it actually sheared off, leaving minimal distortion in the sheet. While the 0.032 sheet with dimpled 3/32 rivets, the rivets finally failed in tension, with the rivet shank actually pulling right out of the factory head (leaving a small donut or rivet head in the dimple). In all cases it seemed that much of the tensile load was being transferred to the dimpled surfaces and not just the rivet shank.

Although I don't have any numbers, the joints using regular head rivets started deforming at much lower

(Continued on page 5)

(Continued from page 4)

loads than any of the dimpled rivets. In most cases the regular rivets tore the sheet, kind of a soft failure, while most of the dimpled rivets would break with a bang.

It would be interesting to test some 0.020 and 0.032 material against thicker material, somewhat like the spar / skin. I suspect that the dimpled rivets would fail at a high tensile than regular rivets, but testing would be needed to conform this.

So will it be ok the flush rivet the Glastar wing or not? From my simple testing it looks like it should be ok, but unless a wing gets made and tested, we will never know for sure. One problem with dimpling is that it may make the joint a bit more susceptible to cracking, and it will take more time to build the wing. A flush riveted wing probably won't be any faster than a conventionally riveted wing, but may look a bit nicer.

After all of this, I have decided to flush rivet the wings, with the exception of the rear spar and the root rib.

Mike Thompson #5191
dimpling lots and lots of holes.

On Lycoming Oil Coolers:

RV-List message posted by: "Eustace Bowhay"
<ebowhay@jetstream.net>

I believe I have a couple of posts in the archives on the subject but after reading the current posts thought I could add some additional info from what I have learned and observed over the years.

The engine oil temp on the Lycomings we are using is controlled by the thermostatic valve. This valve threads into the oil filter adapter, it looks like a heavy duty coil spring with a ball on the end. (Not a good description). On the top of the valve it should have the temperature setting stamped into it. This is usually 85C which converts to around 185F.

From what I have been told, on a cold start oil pressures within the engine and cooler can be as high as 300 PSI. This is not indicated on the oil pressure gauge due to where the reading is being taken from. As the engine warms up the spring in the vernatherm valve begins to expand closing of the bypass and forcing more oil

through the cooler to maintain the 185 F setting. I have found that this setting can vary five degrees or so either way. If the oil temperature goes above say 190 F it is telling us that we have reached the limit of the cooler's ability to cool the oil so cooler size and location becomes critical.

The approach I took to it was based on past experience. As there was no standard installation for the RV6 with an 0360 that I was aware of I used some guide lines that I would be comfortable with, safety and reliability being the priority.

I chose to use the Stewart Warner model 8432 because it is one of the most proven coolers with years of use and I had seen it used on other certified installations and have been told it will pressure test up to 600 PSI. The dimensions of the basic cooler is 3 1/2 inches thick, 5 1/2 x 8. With the two 90 degree fittings in the front it becomes 6 3/4 front to back. It is a 9 row cooler. I installed it under the left front engine baffle with a 4 x 5 3/4 opening in the baffle with the inlet and outlet fittings facing forward. There is ample room for it here. I didn't want to cut a hole in the back baffle and have the scat tube in the rear as associated with a firewall mounted installation and possible loss of cylinder cooling efficiency. On the other hand I wasn't sure what my installation would do the the cooling on #2 cylinder. I ran the cooler lines between the cylinders and the intake pipes to the accessory case.

The end result was a pleasant surprise. I use a "Insight Gem" graphic display for engine monitoring and my 0360 is fuel injected. I have total control over my oil temps. Using 75% power for climb and 115-120 indicated the oil temp never exceeds 200, even at take-off temps as high as 95 F. By the time it reaches 195 to 200 you are in cool enough air and the power has dropped so that it returns to the thermo valve setting. In level flight at 65% it will maintain the basic setting flying in OAT as high as 100.

Mounting in this location has no effect on the cooling of # 2 cylinder, all four as basically the same.

Would be happy to help off the list to anyone interested, I also have pictures of the installation.

Eustace Bowhay
Blind Bay, B.C.
Ebowhay@jetstream.net

Do AD's Apply to Experimentals?

Editors note: With many FARs there is ongoing debate about how to interpret them. Such is the case with regard to whether Airworthiness Directives apply to engines or props of Experimental aircraft. The following article appeared in the summer issue of the newsletter published by the Portland FSDO, and provides our local FSDO's point of view..

Maintenance Update

By Gordon Reade,
Portland FSDO

Do Airworthiness Directives (AD's) apply to certificated Engines, Propellers, or parts installed on Amateur Built aircraft? This is a question that has been bantered about for as long as I can remember. Every time we think it is nailed down, someone writes an article that causes doubt to resurface.

The Experimental Aircraft Association's web site (www.safetydata.com) recently published an article by Ron Alexander (May 1997 Sport Aviation), in which Mr. Alexander states "The FAA has further qualified Airworthiness directives as they apply to amateur-built airplanes. Airworthiness Directives cannot apply to any part of an amateur-built airplane unless that airplane is cited along with who should do the work and to what standards." On the same *safetydata* web site, EAA states "Amateur-built aircraft do not have to comply with AD's, however, if you are using a certificated engine, propeller, or component and you wish to maintain that certification, AD's must be complied with. It is permissible to mark the product data plate as being Experimental so as to eliminate the requirement to comply with the AD."

Here is FAA's legal position based on the FARs and a task force report. AD's are not issued against amateur-built aircraft. AD's issued against certified engines, props, and appliances are required. Amateur-built operating limitations require compliance with FAR 91. FAR Part 91.403 requires compliance with Part 39 (AD's). FAR 39.3 states "No person shall operate a product to which an AD applies except in accordance with the requirements of that AD." FAR 39.1 defines a product, or for the purpose of AD's, as an aircraft, engine, prop, or appliance. Advisory Circular (AC) 39-7C further supports this position. It states that "AD's do apply to aircraft in the experimental category... at least as it applies

to parts installed."

What products or appliances may be eligible for an AD? Briefly, if a "product" has an FAA approved parts tag or data plate, an AD issued against it would apply. This is regardless of whether the part has been modified, altered or repaired in the area subject to the AD.

The EAA says you may mark the product data plate as being treated as experimental. FAR 45, however, prohibits the removal, modification, or installation of any aircraft or certified engine/propeller data plate without approval from the Administrator (FAA). The FSDO is prepared to issue written approval for any amateur builder who wishes to remove/change an aircraft, engine, or propeller data plate. If an amateur builder **legally** changes the data plate to make it his or her own part, the AD will no longer apply. FAR 45 does not prohibit modification of appliance tags by an amateur builder. Always remember that AD's are only issued when an unsafe condition exists. The FAA and EAA both agree that it's prudent to comply with an AD for safety reasons. Failure to comply with Airworthiness Directives could put you, your passengers, and the public at risk.

###

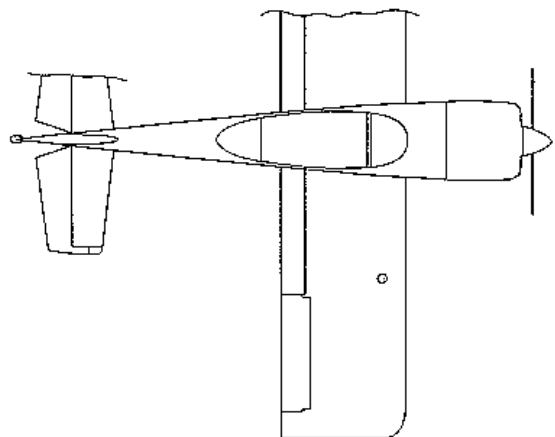

Cheap Seats

By Don Wert

You say the end is in sight but your budget's out of sight..you need something to sit on but the wallet won't hold you and there's no cushion in the credit cards..here's an idea. While wandering through West Marine with an armful of the awful epoxy stuff I noticed this boat seat..hum, looked about the right width and height, decent quality.all it needs is a back plate, some angle and a row of hinge...BINGO: I've got neat looking seats with bottoms that tip up with a small storage space beneath; and it tips forward just like the original! There are limitations like the seat doesn't go to the forward row of hinge on my installation because of aft control stick limits and there is not a lot of post installation adjustment. Time will tell how it wears and feels but for now I have a pair of neat looking seats to get me in the air a bit sooner. The seats are by B&M Manufacturing Co, Inc, \$51 each, at West Marine, Janson Beach. I'm at 464-0378 or rvflyboy@juno.com or in A12 at Troutdale Airport.

Next month I'll be flying!

...Don

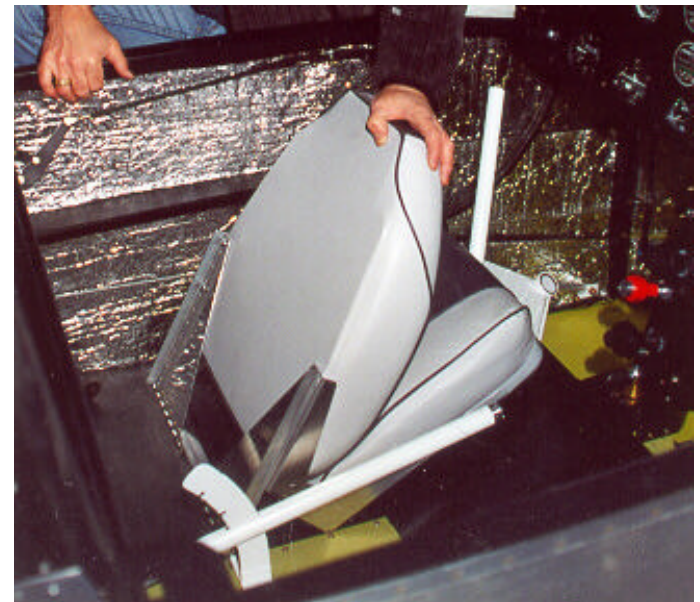



Flying Activities





By Flying Activities Coordinator:

Randall Henderson
503 297-5045
randallh@home.com

The summer fly-out season is coming to an end, but there are still several options as you can see below.

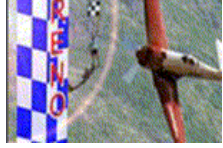
Another thing that bears mentioning is the "Saturday Gaggles". Most people with flying RVs are aware of this by now, but in case you aren't, just get yourself up in the air at 7:30am

and on 122.75 on any Saturday morning and chances are you'll hook up with one or several of the regular "breakfast crew". Sometimes its up to Packwood, or down to Independence, or somewhere further. See you there!

date	description	description	contact
?		Rob Hickman is interested in getting a group together for a day trip to Silverwood ID (S62) . Written up in a recent issue of the Flyer, and billed as the "Northwest's largest theme park". (<i>I happened in there on a recent trip to Sandpoint -- looks neat, and the park is right on the airstrip -- rh</i>). See their web site at http://www.silverwood4fun.com/static	Rob Hickman 503-524-3190 RobHickman@aol.com
Sept 14-17		Bob Neuner and Kevin Lane are going to the Reno Air Races , and are hoping some others will come along, if only to help control Rion :-) Call Bob or Kevin if you'd like to hook up.	Bob Neuner, 503-772-6361 bobn@ims.com Kevin Lane, 503-233-1818 n3773@mciworld.com
November		Mike McGee is interested in getting together an RV contingent for this 15-day Carribbean fly-out trip . This is an annual tour put on by an outfit in Florida called Panama Aviation, and is billed as their 23rd trip. Mike is signed up and is looking for anyone who might want to go (<i>not sure when the sign-up deadline is however -- Mike?</i>)	Mike McGee 503-534-1219 jmpcrftr@teleport.com
?		Haven't quite given up on the idea of a group fly-out camping trip this summer, but the weekends just keep on getting taken up by something else. Don't wait for me on this one, if anyone else wants to do something like that feel free. Otherwise if I come up with something I'll let y'all know!	Randall Henderson 503-297-5045 randallh@home.com
Sept 4-5		Local breakfast/lunch: There are usually local breakfast/lunch fly-outs during Vans Homecoming. Jerry VanGrunsven normally leads at least one of these flights so check with him at the fly-in.	Jerry VanGrunsven 648-3464

Home Wing Tool Policy

Reminder; at the recent meetings various methods of keeping our group's tools from loss and abuse were discussed. In the end we decided that we would not initiate deposits, use fees, or personal escorts. What we decided was...

- Everything goes through Brent — do not give the tool to another member.
- Brent will keep an accurate sign-out sheet for each item so he knows where it is at all times.
- Brent will inspect all tools upon their return. If there is any damage he will ask you to pay for the repair (with the threat of public humiliation if you fail to be a grown-up).
- That we are buying new aircraft weighing scales for the group.

The ability to have occasional use of these expensive tools is a real membership benefit, let's respect the group's assets.

...Randy

EAA Technical Counselors

We have a new technical counselor — Randall Henderson. That makes three tech counselors in the group who have RV experience (that we know of):

Randall Henderson

503-297-5045, randallh@home.com

Dave Lewis, Sr.

503-690-8237

Don Wentz

503-543-2298, jwentz@columbia-center.org

Please drop a line to the editor if you know of others.

Reminder: New E-mail Address for Editor

Please note my new e-mail address for all correspondence... randy@rv-8.com (easy to remember, huh?)

1/1/2001

Builder's Bookstore

for the builder, technician, & pilot

[HTTP://WWW.BUILDERSBOOKS.COM](http://www.buildersbooks.com)



Van's RV Specific

18 Years of the RV-ator	\$27.95
Orndorf Construction Videos	full set
Van's preview plans/manuals	RV-4,6,8
Aiming High	17.95
The RV-Story - VHS	10.00

Other RV Appropriate Titles

Aircraft Sheet Metal	\$18.95
43.13-B Accept. Methods	18.95
Bingelis - Sportplane Techniques	24.95
Bingelis - On Engines	24.95
Sky Ranch Engineering Manual	19.95
Aero Electric Connection	32.00
Fiberglass 101	25.95
AC Painting 101	25.95
Speed With Economy	24.95

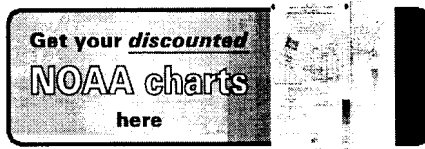

Sectionals	\$6.95
WAC Charts	6.95
TAC Charts	3.95
Planning Charts	4.45



Other RV Appropriate Titles

Lycoming Operator's Manuals	\$19.90
Aircraft Auto Engine Installation	19.95
Instruments & Avionics	23.95
Taming the Tail Dragger	9.95
Builder's Log Book	4.95

Complete sections for:

- General Airframe Techniques
- Sheet Metal
- Composites
- Wood Working
- Fabric
- Aircraft Welding
- Engine Selection
- Engine Installation
- Engine Maintenance
- Engine Accessories
- Electrical and Panel
- Paint & Interiors
- Self Design & Engineering
- A&P Training & Testing
- Sport Flying Skills
- Sport Flying Stories
- Choosing a Homebuilt
- Log Books
- NOAA Charts

See our secure web site for a complete listing with detailed descriptions. Always in stock. Same day shipping. Never a packing or handling fee. Prices current as of 3/10/00.

Builder's Bookstore

<http://www.buildersbooks.com> for book and video info call 970 887-2207 PO Box 270 Tabernash, CO 80478

CLASSIFIEDS...

Classifieds are free to Home Wing members. Ads will run for three months. Send to editor by e-mail or mail. Renewals ok, just let editor know. Date at end of the ad is last month ad scheduled to run.

FOR SALE

RV6A KIT.— Empennage (finished), Wing Kit with pre-finished PHLOGISTON SPAR. \$5,500., I also have many high quality tools available. Bill Anderson 949-240-4842, email hobihawk@aol.com, 12/00

RV-6 Empennage & Wing kits — Empennage partially completed, wing kit is Steve Barnard's fastbuild. Contact Rod Kimmel, 503-985-0606, 8/00

RV-6 Prepunched Empennage and assorted tools - All items offered individually at ~85% of (~15% off) their original price. Or buy all items at 80% of their original price. The listing below will supercede any math error. Work started on horizontal stabilizer - frame is drilled, almost ready for rivetting. Jig is wood - 2x4, 4x4 and plywood construction. E-mail for pictures of jig and/or work done on horizontal stabilizer. Or call for more information. George Johnson, Colorado Springs, CO, (719) 622-9479 <mailto:geoandlisaj@yahoo.com>, 9/00

- Special letter drill used to ream rear spar bolts/straight reamer for rear spar/
- 1/2"per foot taper reamer

Contact Kevin Lane, 503-233-1818 or n3773@mciworld.com. 12/00

Lowrance Airmap 300 — For sale at \$575.00. Greg Halverson 503-591-0105, 12/00

Duckworks Landing Lights - Retro-fittable, light, easy installation. Kits start at \$69, discount for Home Wing-ers. Don Wentz, 503-696-7185

BACK ISSUES are available at \$2.00 each including postage for hardcopy. Limited availability, contact newsletter editor. Adobe Acrobat versions free to members.

WANTED

Flying RV-4 or RV-6 — I am looking to buy a flying RV. I prefer the RV6 series, but would consider a good RV4. If you know of anything, I would appreciate having the seller contact me. Thank you. Jim Hughes jcdewitt@home.com [319] 263-0684 Muscatine, Iowa 9/00

Vendor	Qty	Description	Original Price	Offering Price
Van's	1	RV-6 Prepunched Empennage Kit	1267.00	1076
Brown	1	Taylor Rivet Gun 3X	154.95	131
	1	Jig	125.00	106
ATS/Brown	4	Rivet Sets	41.80	35
Van's	80/20	3/32" / 1/8" Clecos	33.00	28
ATS	2	Buck Bars	29.20	24
ATS/Brown	2	Dimple Dies (3/32" pop & 1/8" standard)	22.90	19
ATS	1	Fluting Pliers	15.95	13
Van's	1	Trim Bundle, etc. (for practice)	9.55	8
Brown	3	Drills 6" & 12"	9.35	7
Van's	1	Riveters Tape 3/4"	5.94	5
		Total	\$1,714.64	\$1,452.00
		20% Off (Purchase all items)	\$1,371.71	

Misc. For Sale:

- 3 1/8" mechanical tach and cable from -6A/160hp. Cable was new, tach rebuilt, used 500hrs, works fine, went to small electric unit. \$50
- Aircraft tire bead breaker, for tire removal

Use 'em!

Members are encouraged to take advantage of the classified section. Since it's free why not take a stab at unloading that unused airplane stuff. Besides, it's kind of interesting to look at all the odds 'n ends for sale.

Please note that the date at the end of each ad is the expiration date. They run for three months and then are dropped unless you want them renewed by notifying me.

...Randy

The Tool Exchange

The Home Wing owns a selection of tools for use by its members. The Toolmeister is **Brent Ohlgren, 503-288-8197**. Call either Brent to arrange use.

Remember:

- All use must go through Brent.
- You are personally (financially) responsible for any damage.

Home Wing Tools
HVLP paint sprayer
Hole template for instrument panel
Wire crimping tool & die
Brake lining rivet set
Tune-up & annual kit (compression checker, mag timing light, timing dial, mag adjustment tool, plug gapper, high voltage cable tester, and plug vibrator cleaner.
Aircraft scales — allows you to accurately weigh your beast and also determine CG.
Oil filter cutter—custom make by Stan V.

Other benevolent members also have tools they may be willing to loan. Let the editor know if you have jigs, tools, shop space, etc. to loan, exchange, or otherwise provide — at no cost — or if you are looking for something specific to borrow. And whether your item is listed here or not, go ahead and bring it to the meeting.

Item	Owner/lender	Phone / e-mail
Custom cutting wheel man-	Stan VanGruns-	
Prop tach (calibrate your	Butch Walters	360-636-2483
Engine stand	Don Wentz	503-696-7185
Engine hoist	Norm Rainey	360-256-6192
Surveyor's transit level	Bill Kenny	503-590-8011
Back riveting contraption (large, counterweighted bucking bar and suspen-	Bob Neuner	503-771-6361
Lead crucible (for melting	Doug Stenger	503-324-6993
Table saw taper jig (for ta-	Carl Weston	503-649-8830
48" pan break located at hanger PLS D-10 at Trout-	Kevin Lane	503-233-1818 h3773@mciworl
Lasar T-300 magneto tim-	Randy Lervold	360-817-9091,

Home Wing Newsletter Subscription/Renewal

To join or renew, fill out this form and mail to **Randy Lervold, 5228 NW 14th Circle, Camas, WA 98607**, along with \$10 for renewals or new subscriptions. *Please make checks payable to either Randy Lervold or Home Wing*. If you are renewing you only need to give your name, payment method, and any other information that has changed. Please don't forget your e-mail address and newsletter distribution method. *Use this form for address changes too!*

Name: _____	Spouse: _____
Address: _____	Home phone: _____
City, State, Zip: _____	Work phone: _____
	E-Mail: _____
Project:	Status:
RV-3 <input type="checkbox"/>	Empennage <input type="checkbox"/>
RV-4 <input type="checkbox"/>	Wings <input type="checkbox"/>
RV-6 <input type="checkbox"/>	Fuselage <input type="checkbox"/>
RV-6A <input type="checkbox"/>	Finish kit <input type="checkbox"/>
RV-8 <input type="checkbox"/>	Flying <input type="checkbox"/>
RV-8A <input type="checkbox"/>	
Payment:	Newsletter
Check: <input type="checkbox"/>	Distribution:
Cash: <input type="checkbox"/>	Mail <input type="checkbox"/>
Info change only: <input type="checkbox"/>	E-mail (pdf) <input type="checkbox"/>

Home Wing – Van’s Air Force
 Randy Lervold, Editor
 5228 NW 14th Circle
 Camas WA 98607

Disclaimer: The Van’s Air Force Home Wing newsletter is in no way a publication of Van’s Aircraft or any other corporation. All products reviewed or mentioned are not necessarily recommended for use by the Home Wing, but are included for informational purposes only. All builders tips represent only the means by which the builder whose name is associated with the tip chose to build his/her aircraft. Builder’s tips are not meant to replace the plans and instructions from Van’s Aircraft. All builder’s tips are presented only as a source of information and a forum for exchange and the sharing of ideas and construction methods. NO responsibility or liability is assumed, expressed, or implied as to the suitability, accuracy, safety or approval thereof. Any party using the suggestions, ideas, or examples does so at their own risk and discretion and without recourse against anyone. The editor of the Home Wing newsletter and the builder’s tips submitters are not responsible for any product or builder’s tips misuse, incorrect construction, or design failure, nor any other peril. Any material printed within may be reprinted without permission, but please give credit to the original source and author. If the original source is not the Home Wing newsletter, it is not necessary to credit the Home Wing newsletter, only the original source and author. The Home Wing newsletter is published more or less monthly. Subscriptions are \$10/year. Complimentary issue for new builders upon request. Mail subscriptions, ideas, tips, tricks, and articles to the newsletter editor.

Home Wing info:

Newsletter editor & publisher	Randy Lervold 360-817-9091, randy@rv-8.com
Membership	Randy Lervold 360-817-9091, randy@rv-8.com
Meeting coordinator	Randall Henderson 503-297-5045, randallh@home.com
Flying activities coordinator	Randall Henderson 503-297-5045, randallh@home.com
Annual fly-in leader	Don Wentz 503-543-2298
Home Wing web site	www.edt.com/homewing
Webmaster	Randall Henderson randallh@home.com