

HOME WING

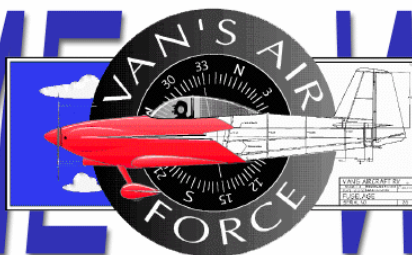

Newsletter of the Home Wing of Van's Air Force — Builders and Fliers of Van's RV Series Aircraft



Brent Anderson's RV-4 looking good with it's new Craig Robertson paint job. Those of us who saw Brent's plane in person at the May meeting know this picture doesn't do it justice!

Events Calendar



Meeting coordinator:
Randall Henderson
503-297-5045
randallh@attbi.com

MONTHLY MEETING:

(2nd Thursday every month, various locations, 7:00 pm)

Place: *No meeting for June due to annual fly-in*

Future meeting schedule:

June: Annual Fly-in, Scappoose
July: Joe Blank RV-6, fly-in @ Skydive Oregon
Aug: Dean Psiropoulos RV-6A, fly-in @ Sunset
Sept: Pat Casey / Glen Miller RV-9A, Orchards, WA

Meeting places are always needed: if you'd be interested in hosting a meeting please contact Randall Henderson at 503-297-5045 or randallh@attbi.com

EAA CHAPTER 105 Pancake Breakfast:

First Saturday of every month at Twin Oaks Airpark, 8:00 am, \$5.00 (usually lot's of RVs to look at too!)
This month: 6/1/2002

EAA CHAPTER 105 Monthly Meeting:

Third Thursday of every month at the EAA 105 hangar/clubhouse, Twin Oaks Airpark, 7:00 pm.
www.eaa105.org for details
This month: 6/20/2002

EAA CHAPTER 902 Monthly Meeting:

Second Wednesday of every month, Mulino Airport in the OPA building. Info: Bob Boring at 503-661-7627
This month: 6/12/2002

Newsletter Delivery

We encourage those still receiving black & white snail mail to switch to e-mail delivery. Some of the benefits include...

- **Faster delivery:** you receive the newsletter 2-4 days ahead of snail mail.
- **Full COLOR:** with the increasing use of photos this adds another dimension you don't want to miss.
- **Storage flexibility:** you can print it on your own printer, or leave it stored electronically, or both.

If you're interested e-mail delivery but unsure, let me send you a test copy. Just send me an e-mail (randy@rv-8.com) and I'll send you a test copy.

829RW to Vegas

By Charles Rice

Before I started flying Robin Wessel's RV6A, I thought flying Evergreen Aviation's Piper Cub to Beacon Rock and back was a pretty long flight, at an hour. If I had a morning free and the plane was available and the winds were light, I'd go around St. Helen's in just over two hours. Then I started flying Robin's plane. I still have not found greater joy in flying than while in a Cub with the door down and the window up on a nice summer day, but it is a painfully slow way to get from point A to point B.

A good excuse for my first REAL cross country presented itself when I was invited to a bachelor party in Las Vegas. A friend on the invite list who lives just south of SFO though flying down sounded great, so we made some plans, researched the cheapest same-day airline tix for a bad weather back-up (Southwest at ~\$300), and crossed our fingers.

Thursday afternoon the weather was fine, so I snuck out of work a few minutes early and 30 min later I was taxiing for rwy 30 straight out. I programmed the Garmin 300XL with about 8 waypoints down the coast, but the navigation was low tech until 10nm north of SF. Take off and veer a little to the left, find the ocean, turn south and follow the coast to the big red bridge. Yes, the Golden Gate Bridge is actually Rustoleum red, much to the surprise of some tourists. "Golden Gate" is actually a reference to the mouth of the SF bay, California being the "Golden State". The last 15 min were a little harder than I had hoped, because as is typical in the summer in SF the coast and most of SF were socked in with dense fog. (Hence the Mark Twain quote, "The coldest winter I ever spent was a summer in San Francisco".) About 15nm north of the City I took a quick peek under the layer, but could see that it went right down to the waves, and the top was 2,500'-ish. I checked my destination ATIS at San Carlos / SQL and listened to the tower chatter enough to confirm that once I got around the Class B I'd have no trouble getting down. The SFO

(Continued on page 4)

Builder's Motivation Day

Builder's Motivation Day was held as planned on Saturday, May 11th. I'm pleased to report that it came off beautifully. We had spectacular weather, all aircraft and riders showed up on time, and no incidents. Eight aircraft flew twenty two rides, all Home Wing members and RV builders (or significant others).

A very special thank you to our pilots who so generously donated their time and fuel:

- Dan Benua**
- Bill Drake**
- Harmon Lange**
- Brian Moentenich**
- Brent Ohgren**
- Miles Towner (Van's Aircraft)**
- Stan Vangrunsven**
- Jerry Vangrunsven**

Noticing that there were more riders there with a longing look on their face, Brent and Stan even flew four rides each — well above and beyond the call! Judging from the smiles and comments after the flights I'd say the mission of the event was fulfilled. Let's discuss it at our next meeting, but maybe this can be an annual event.

...Randy



TOP: Jerry V. belts in an excited rider.
MIDDLE: riders wait their turn while enjoying the spectacular day.
BOTTOM: Home Wing pilots arriving and departing giving 22 rides.
 Photos by Ed Wischmeyer

(Continued from page 2)

ceiling is 10,000' so I could have gone over, but staying under the 3,000' floor only forced me out over the ocean a few miles. Normally I also could have gone inland a bit and flown a "Bay Tour" route which takes you down Hwy 101 within 1 nm of SFO at 1,000' to 1,500', but I could hear from the radio chatter that VFR requests through SFO were getting denied due to marginal VFR. So I throttled up to minimize my feet-wet time, and easily skirted the class B to the west with the assistance of Robin's two exceptionally useful GPS units, and found my airport against the clutter with out any trouble. Landed about 6p with 4.3 hrs on the Hobbs, and I got worked over for about \$2.75/gal. Spent a lovely evening with my buddy and his wife and kids, walked around his house with his new baby, and got to bed early.

The weather the next day sucked for sight-seeing, but was fine for VFR. Did some web based weather checking at the FBO and departed with my buddy about 10a. We stayed under the thin 3,000' barely broken overcast until we were just south of Monterey, but everything was gray and murky, so we got on top at about 4,500' and headed a little further south following the coast on the GPS hoping the overcast would break up. It didn't. Gave up on seeing the coast and punched in Direct To BFL / Bakersfield.

After topping the tanks we got a courtesy car that was in no danger of being stolen for a quick run to McDonalds, maintaining our tradition since high school that it's not really a road trip until you've gone to a McDonalds. 2.3 on the Hobbs, and 15.3 gallons.

Back at the FBO we looked at the latest radar and satellite images, which showed no rain but plenty of cloud cover. This was validated by surface observations at airports near our intended route, which was looking about as likely monkeys jumping out my (). Found a CFI at the FBO and grilled him about his experience getting from BFL to Vegas. More bad news from him, so we headed for his first choice alternate to the south, Tehachapi / TSP. We flew up the valley leading to TSP nice and slow and we were 5 nm from the airport, but flying 500' under the solid overcast, and still ~300' below the airport. We could see a bit of sunlight on

the other side of the pass, but the valley was getting pretty narrow, and we were just a few minutes from the point of no return. A few nm further and we'd be trimming tree tops if we cranked a U turn. So, we cranked a U with plenty of room between Robin's four layer pearl paint job and the tree tops, and I started thinking aloud about how long it might take to drive the courtesy car from Bakersfield to Las Vegas. We saw some sunny patches 20mn or so to the south west where the overcast turned to broken with tops at ~9,500'. Walt asked if we could get that high, and I told him we could get that high in about 5 minutes. Checked the weather to the east to make sure we would not be VFR on top for too long, and enjoyed a 1,200 fpm climb to about 10,500' to clear blue skies over a solid bank of clouds to the east stretching for miles, and turned toward Palmdale / PMD which was reporting 30kt winds right on our (). (For those of you who did not see the movie that completes the "monkeys" phrase above). 170-180kt ground speeds at 2200-2300 rpm and I was reminded that we were not in a Piper Cub. Just like on the satellite images, the solid turned broken, then scattered, then clear, and we cruised toward Henderson Executive / HND in a medium chop. I warned Walt that we better get our seatbelts nice a tight, but we only had about 30 seconds of significant turbulence as we descended through a layer. Winds were 20kts gusting to 25 at HND, but not too far off the runway heading. Kept me busy on short final but was no trouble. I mentally thanked Robin for going with the 6A. 2.5 on the Hobbs and 16.0 gal.

Like the other FBOs, the people at HND were very pleasant, and saved us \$60 by driving us over to Enterprise Rent a Car so we could get the \$10/day for 3 days weekend rate instead of the \$30/day if they deliver the car to the airport. At \$10/day the car was a deal just for the drive into town and back out. You can throw a wadded up \$10 bill further than a cab in Vegas will take you for the same \$10.

Vegas and the Bachelor Party were great fun. Except for "golf", which was more like "drink your weight in beer". For me, 18 holes of golf or 18 beers are about 16 too many. One saving grace was we played a course on Nellis AFB, with the course very close to the end of the active runway. Saw

many F16 and F18 departures, a few C130s and C131s, one C5A, several F117s, and one B2.

Sunday morning we awoke to clear skies and light wind, saddled up and wound our way between 8,000' peaks and over 4,000' passes for Furnace Creek airport / L06 in Death Valley, at minus 233' MSL. Got out of the plane, figured if we stayed long it was going to get hotter than hell, so we got back in the plane and departed. I generally avoid silly risks that leave little margin for error, but just after departure I just could not pass up the chance to haul () for several miles across a dry lake bed with the altimeter reading significantly below sea level. Skirted some Restricted Areas around China Lake AFB en-route to Kern Valley Airport / L05, which was lovely.

Unfortunately, we got there at the lunch rush and could not get anyone to take our money in exchange for food or av-gas, and gave up after about 15 minutes of waiting and calls to our spouses. Followed the river valley west towards Bakersfield, direct across the Central Valley to Oceano, and up the coast. The weather this time was beautiful. Circled Hearst Castle, overflew Monterey Class C, and cut over the mountains into the Silicon Valley at Santa Cruz. A few more minutes and we were 10nm south of San Carlos. That is busy airspace, and I was glad to have a second set of eyes in the plane. As near as I can remember, an exact quote from another pilot inbound to San Carlos, and potentially converging with us, was "I, um, am near the, um, freeway (there are several in the immediate vicinity), inbound with ATIS (not "Whiskey" or "Papa", but "ATIS"), and um, I'm familiar with the airport" ATC was very nice to him, and pretty quickly got some useful information out of him. I was reminded of my first solo attempts to talk to use the radio and fly a plane, which for me were close to mutually exclusive for a while. Now I try to use my best gravelly ATP imitation, and use cool phrases like "no joy". Unless I'm under some stress, then my voice goes higher and "um" sneaks back into my phraseology. 4.3 on the Hobbs and 27.2 gal from Vegas to SF with two huge detours. Not bad. Even when driving significantly over the speed limit it used to take us better than 12 hours to make the drive, and we didn't get to see Hearst Castle or Death Valley.

Walt had done almost all the flying but for the take offs and landings since leaving Las Vegas, so I was still quite fresh. Another check on the latest satellite images showed great weather all the way back to Portland, and I departed SQL at 4p. Back around SFO Class B, over Napa Valley direct Red Bluff, more or less followed I-5 past Shasta to Ashland, and then direct UAO for gas. Popped over to HIO, put the plane away, and was on my way home by 9p with another great road trip under my belt and 17.4 hrs of Real Cross Country time in the log book.

Thoughts on my first Real Cross Country:

- It required a lot more attention to detail than I expected. Check the map against the GPS, identify the close airports on the ground if you can, dial in the next nearest ATIS / ASOS and CTAF, scan the engine monitor, check your fuel, correct your altitude and heading. Repeat every 4 minutes until you are 10nm from your destination airport.
- Nevada and California are just as big in a plane as they are in a car. 150kts is a lot faster than 70 mph, but it isn't Warp 5, which I suppose I was expecting.
- Driving a car in any conditions is at least an order of magnitude less stressful than flying a plane near bad conditions. As we drove from Henderson toward the Strip, I was thinking to myself, 'man, this driving stuff is REALLY easy'.
- Flying with another aviation savvy person is much less tiring than flying solo.
- Just under three months until the Ultimate Cross Country destination of Oshkosh.

...Charles

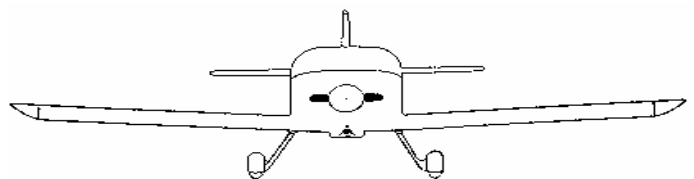

Non-Aviation Events

By Bob Neuner

My wife and I like to fly together, but not always to fly-ins. I don't understand it...how could you not want to spend, whole days at a time, doing nothing but flying, looking at, and talking about airplanes? Anyway, here are a few events for those who want a change of pace.

May 11-18 – Moving Waters Festival, Moab Utah; Lectures, exhibits, art fair and some of the most beautiful natural geological formations in the world. Moab is sandwiched between two of the countries most popular national parks, Arches and Canyonlands. If nothing else, the scenery is worth the trip.

June 14-16 – Oregon Mountain Cruise, Joseph OR; Car show, classics, antiques, hot rods, and custom cars. There's a 50's dance and other stuff. Never been... sounds like fun!

June 22-30 – Reno Rodeo, Reno Nevada; If you don't like cars, maybe you'll like wild horses. Many, many events. (775-329-3877)

July 27-28 – 19th Annual Paisley Oregon Mosquito Festival; This is one of those "old timey" community get togethers. We went last year and had a great time. Horseshoe competitions, barn dances, a small rodeo, art exhibit, and many other events. They just repaved and lengthened the airport runway. Paisley couldn't be friendlier and the locals really appreciated everyone that flew in. (OK if you still want a little aviation, Tom Ellsberg performs aerobatics in his "One Design".) See their website www.paisley.presys.com/mosq.htm.

August 3-11 – "Hot August Nights, Reno Nevada; One of the largest auto events in the country. Hundreds of hot rods, customs, and exotic cars. I've gone for the past couple of years, and its all the cool cars you would ever want to see.

August 9-10 – Tahoe Concours d'Elegance boat show. Beautiful boats on the beautiful lake Tahoe Nevada. (530-581-4700)

August 10 – "Bronze, Blues, & Brews, Joseph OR; Good Blues music, food, and microbrews.

August 26-September 2 – "Burning Man", Black Rock Desert Nevada, This is probably the most bizarre event ever. Its billed as an art fair. Its really a gathering of some of the strangest people on the planet...or the maybe the galaxy. They set up a runway and a tie down area for pilots, right on the "Playa". This event is huge! People from all over the world attend. A 30 foot wooden man is constructed and burned on the full moon. Bring masking tape to cover every opening and crack on your plane. The dust gets everywhere. See their web site www.burningman.com.

September 25-29 – Street Vibrations, Reno Nevada; Big Bad Harleys and lots of leather. (1 800 200-4557)

September 10-13 – Pendleton Roundup. Wild animals and a wild time. (1 800 45R-odeo)

??? – Prospect Bluegrass Festival, Prospect Oregon; Unfortunately their website offered no dates or phone number. Prospect has a great State airfield within walking distance from

the historic Prospect bed and breakfast. Some great hiking trails are right off of the airport. You really don't need an excuse to visit this beautiful area. (Don't forget to sign in each time you visit! The airport needs the support. Also mention that you flew in if you eat at the café.)

...Bob & Marilyn

An Airport Gathering June 29, 2002 - 10:30 to 4:00

This is to let you know of a airport gathering that a group us with property on the Randle-Kiona Airpark have arranged. We invite you to fly-in for some conversation, tire kicking, and general aviation enjoyment. We will be congregating about 10:30 and plan to have some drinks and a limited amount of food (probably hot dogs). If you want to fly in and eat, feel free to bring something along. Our facilities are limited, but there is plenty of parking, some restrooms and really nice views!!

The area, though near the mountains, is quite easy to fly around and there is some beautiful scenery. Both Packwood and Morton which are each a 10 minute flight away have airports that are within easy walking distance of town and a selection of restaurants.

Where: Randle-Kiona Airpark, found on the Seattle sectional between Mt. St Helens and Mt. Ranier. The airstrip is about 5 miles SW of the town of Randle which is between Morton and Packwood on highway 12. Highway 12 is the one that crosses over White pass to the east. The identifier is WN55, however, since it is not a paved strip it is not in most GPS databases

Airport Specifics: 2500' of fine pea gravel, quite smooth surface. Runway is oriented 07/25. There are some trees at the east end and an excellent approach from the west. Preferred landing in a no wind situation is 07. Local traffic advisory is on 122.9, use conventional LH pattern, airport elevation is 950'.

Weather Decision: You can reach me on my cell phone at (206) 910-7527 on Friday evening or Saturday morning if there is a question about the weather. Alternatively, you can call Steve Lorenz at (360) 497-2245. He lives there full time and will be on site while I may be in route.

Disclaimers: This is a private notification of an unofficial gathering at Randle-Kiona Airpark. Only those to which an invitation has been extended may attend. All people flying in do so at their own risk and neither myself or the Airpark may be in any way held liable.

Walt Cannon

Home (206) 524-7221

Cell (206) 910-7527

grnlake @earthlink.net

Flying Activities



Flying Activities Coordinator:

Randall Henderson, N6R
randallh@attbi.com, 503-297-5045

Next up: **Langley Aero Club and VAF Canada Wing's RV Fly-In, June 8th** up at Langley BC, just across the border from Blaine WA. There'll be seminars

from the likes of Eustace Bowhay and Bart Lalonde, awards, aerial demos (Navion formation team), and camping on-field. They're hoping to get a good showing from their US neighbors, so let's not disappoint them! Randy and Randall and wives are planning to go, and Jake Thiessen has also signed, and the word from down south is that Gary Sobek and Paul Rosales will be up from the SoCal wing. Should be a good time. Contact Tedd McHenry, 604- 574-4764, tedd@mchenry.ca, web site www.vansairforce.org/CYNJ.

Of course **June 15** is our own **Northwest RV Fly-In at Scappoose**. We didn't mail flyers this year, so we're depending on people finding out through the various calendar pages and newsletter blurbs. So if you know anyone who might not know about this event, be sure to fill them in. And don't forget to sign up for a work shift! Don Wentz, 503-543-2298, jwentz@columbia-center.org.

Several of us will again be taking off from Scappoose for **Salmon Arm** and their Father's day event on **June 15-16**. Randy and Cassie Lervold, Randall and Jeanne Henderson and Dan and Sun Benua have all expressed an intention to go. In the spirit of "safe and sane formation flying", we're hoping to keep it to 2-ship (or less) flights this time, at least unless/until more of us have had a chance to formally practice FF together (remember that whole "safer formation" thing we've been talking about at the meetings?) That being said, it would probably be useful to have a last minute briefing, so let's get together around the picnic tables around 1:00. Probably shoot for an ETD of 2:30, in order to get up there, through customs and up to Salmon Arm in time for their Spaghetti Dinner at 6:00. They're asking for a head-count so if you plan to go, please let Randall know and he can forward the info to the organizers. For border crossing info, check the May newsletter or the Home Wing web site.

The **EAA Chapter 105 Poker Run** is planned for **Saturday June 21st**. This is the first fly-out type event for the chapter in a long time, and it looks like fun. The plan is to show up at Twin Oaks any time starting around 10:00 and pick up your *free* t-shirt (this step is optional – you can head off from your home airport and make the other stops, then wind up back at Twin Oaks for the finish). Fly to the first four airports in any order and pick up a playing card at each. The airports/pick-up spots are Independence (Annie's), Scappoose (Transwestern), Tillamook (Air Museum Café), and McMinnville (Cirrus Aviation). Get back to Twin Oaks by 2:00 to pick up your fifth card, compare your hand with the others (5 card stud), and hang out for the BBQ and awards presentation. This is NOT a race – you just have to fly to the various airports, get a card at each, and get back to Twin Oaks by around 2:00. So take your time and have fun. First prize is a handheld radio. Bring a side dish or dessert for the BBQ if you can. For more information, see the EAA Chapter 105 newsletter, or contact Jenny Hickman, 503-524-3190.

Still building and tired of being left behind?

You don't have to be! There are often empty seats, so don't be shy about asking. The **oregon-rvlist** email list is the perfect forum for still-building types to ask for empty seats (and for flyers to offer them). To subscribe, send email to oregon-rvlist-subscribe@yahoogroups.com, or visit groups.yahoo.com/group/oregon-rvlist. Or just speak up at the meeting.

The **Cactus Pete Air Race** at Jackpot, NV is **July 5, 6 and 7** this year. Note that the event schedule is shifted up a day from previous years – that is, arrive/register on Friday, race on Saturday, awards Saturday evening, go home on Sunday. So far it looks like Kevin Lane, Bob Neuner, and Randall Henderson will all be going. Call Cactus Pete's at 800-821-1103 to make room reservations. There is no "block" of discounted rooms so far, but that may yet happen, so ask about it when you call. And even if you don't get one initially, call back a few weeks before the event and check – you might be able to switch to a discounted room. Either way, make your reservation soon, as they are filling up. And please let Randall know if you plan to go.

EAA Arlington is **July 10-14**, so put in for a couple of vacation days and plan to come up and join those of us (too

(Continued on page 8)

EAA Technical Counselors & Flight Advisors

The following Home Wing members have volunteered as technical counselors under the **EAA Technical Counselor program**:

- **Dan Benua** 503-621-3323 danb@synopsys.com (EAA Ch. 105, RV-6A builder, Hillsboro-Scappoose-Portland area)
- **Jerry Darrah** 503-254-9992 (EAA Ch. 902, A&P, Glastar builder, Portland-Troutdale area)
- **Randall Henderson** 503-297-5045 randallh@attbi.com (EAA Ch. 105, RV-6 builder, Hillsboro-Portland area)
- **Randy Lervold** 360-817-9091, randy@rv-8.com (EAA Ch. 105, RV-8 builder, Vancouver/Portland area)
- **Dave Lewis, Sr.** 503-690-8237 (EA Ch. 105, multiple RV builder, Hillsboro-Portland area)
- **Brian Moentenich** 503-666-7518, Brian.L.Moentenich@usace.army.mil (EAA Ch. 902, RV-6A builder, Portland-TTD area)
- **Mike Robertson** 503-681-5537 mrobert569@hotmail.com (FAA A&P w/IA, RV-8A builder, Hillsboro-Portland area)
- **Bill Truax** 360-582-0558 goonybrd@olyphen.com (Sequim-Port Townsend WA area)
- **Don Wentz** 503-543-2298 jwentz@columbia-center.org (EAA Ch. 105, RV-6 builder, Scappoose-Portland area)



The following Home Wing members have volunteered as flight advisors under the **EAA Flight Advisor program**:

- **Dave Lewis, Sr.** 503-690-8237 (EA Ch. 105, multiple RV builder, Hillsboro-Portland area)



(Continued from page 7)

many to list!) who like to arrive during the week and camp under our wings (or in the main camping area with slightly heavier accommodations) at that fun grass-roots aviation event. www.nweaa.org.

Oshkosh is **July 25-29**, and this year is their 50th anniversary. If random conversations with other Home Wingers are any indication, they will see a good RV turnout from this part of the country. www.airventure.org.

That **Camp-out** we've been hoping to put together for the past several years might just happen this summer. Anyone who's interested in that (and isn't too worried about chipping their paint on a dirt or gravel strip), talk to Randall. At this point we're tentatively planning on Red's Horse Ranch, sometime in **July or August**.

And as always, the "breakfast club" meets on **122.75** at 7:30 a.m. Saturday mornings (weather permitting). Get up in the air and on frequency and we'll decide where to fly for breakfast!

...Randall

Fly-in Staffing

Leaders for all the main functions have stepped up, thanks! They still need help however. Please contact them in advance, or on the day of the fly-in to help. You can reach me at 503-543-2298 or jwentz@columbia-center.org.

...The Duck

Team	Leader
Setup/takedown	Joe/Char Miller, jwmcmm@aol.com
T-shirts	Mike Wilson, james.mike.wilson@intel.com
Food	Janet Wentz, jwentz@columbia-center.org
Aircraft parking	Scott Orr, aviatorr@hotmail.com
Auto parking	Jeff Jasinsky, jasinsky@pacifier.com
Ground radio	Mike Robertson, mrobert569@hotmail.com
Publicity	Randall Henderson, randall@edt.com

CLASSIFIEDS...

Classifieds are free to Home Wing members. Ads will run for three months. Send to editor by e-mail or mail. Renewals ok, just let editor know. Date at end of the ad is last month ad scheduled to run.

FOR SALE

RV-7 Tail Kit — Includes electric trim and will throw in the Cleaveland alignment jigs. The kit has only been inventoried, nothing has been touched. Corby Sommer-ville 360-683-6774, 9/02

RV-6A QB kit - Purchased new in 1999 from Van's. Never touched. Tip-up canopy, tricycle gear, needs finish kit. Also includes wing cradle. \$14.5K. Contact Ron at 503.696.2093 or email: ronstory@xprt.net, 8/02

RV-8A partially finished — 99% completed RV8A..0320, 160hp, osmoh, C/S prop, upholstery, painted, built from quick build. \$61,500. Located aurora, OR. Contact Jolly Dawson at 503-678-3343, 8/02

Whelen A490 ATS DF Strobe Power Supplies—I have two of them. They work on 14-28 volts. \$240 plus shipping from Eugene. Wally Anderson 541 683 2328, wallyander@earthlink.net, 5/02

Aviation Book Set — I have 20 new Time/Life books "EPIC IN FLIGHT" for sale at \$150 for the set. Call Judy VanGrunsven 503-648-3464, 9/02

Squirrel cage fans Two each 12.5" x 23.5" 110v, 1/3 hp. Great for clearing the paint fumes out of your garage/paint booth in a hurry. \$30 & \$45. Chris 503-233-5863, 7/02

Duckworks Landing Lights - Retro-fittable, light, easy installation. Kits start at \$69, discount for Home Wingers. Don Wentz, 503-696-7185

EAA CHAPTER 902 is selling Air Force A-2 leather jackets to raise money for it's hanger & educational building fund. Sizes range from XS to 3XL in Dark Brown or Black. Only \$98 (tall sizes \$108) and you help your EAA chapter. Order now for the winter, Christmas, or for a friends gift. Contact Gary Dunfee 503-631-7262 garydunfee@earthlink.net or Jim Wasson 503-655-3301. We'll also take donations for the hanger fund and give you a receipt for tax purposes.



WANTED

Parts Wanted — I'm finishing up an abused RV-4, I need vfr flight instruments and engine instruments for an O-320. Also, engine baffles, exhaust, carb, prop and spacer. Mark, 719-276-3034, pawnee235@yahoo.com, 6/02

Partner For RV-4 — Seeking partner to purchase flying RV-4 with. I am a fairly low time pilot and have found an RV 4 locally that is not IFR equipped that is to be for sale for \$48K. I believe this to be a sound unit and am looking for a partner to buy it. Ed Barrow edbarrow@casgen.com, 6/02

WANTED: Women pilots, to give Young Eagle Rides to girls in the AWSEM Program. Please call: Marcy Lange @ 503-397-6916 or e-mail: marcy@langair.com, 6/02

RV-6A WANTED — We are seeking to buy a completed RV-6A that the builder is proud of. We are not particular, as long as it has a O320 or O360 engine. CS prop is not essential. The ones we have had "pre-buys" on, were not built well, or were modified by the builder and not in accordance with Van's specs. Interested parties can contact me: Jim Dean 530-271-7355, james-dean@msn.com, 7/02

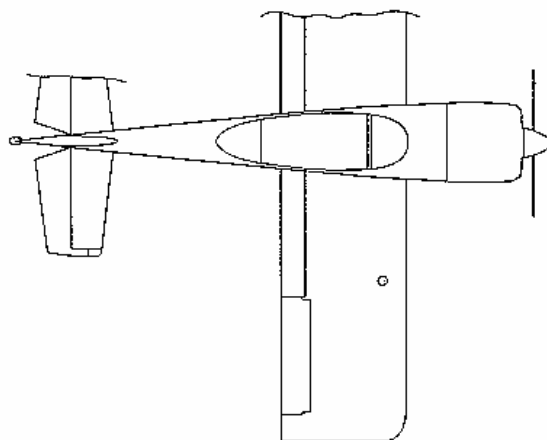

THE TOOL EXCHANGE

The Home Wing owns a selection of tools for use by its members. The Toolmeister is: **Brent Ohlgren, 503-288-8197, obrento@aracnet.com**. Please observe our Tool Policy:

Home Wing Tool Policy

- Everything goes through Brent — do not give the tool to another member.
- Brent will keep an accurate sign-out sheet for each item so he knows where it is at all times.
- Brent will inspect all tools upon their return. If there is any damage he will ask you to pay for the repair (with the threat of public humiliation if you fail to be a grown-up).

The ability to have use of these expensive tools is a real membership benefit, let's respect the group's assets.

Home Wing Tools

HVLP paint sprayer, turbine type. Includes gun and air turbine.
Hole template for instrument panel.
Wire crimping tool & die large gauge wires (e.g. battery leads)
Brake lining rivet set.
Tune-up & annual kit (compression checker, mag timing light, timing dial, mag adjustment tool, plug gapper, high voltage cable tester, and plug vibrator cleaner.
Aircraft scales — allows you to accurately weigh your beast and also determine CG.
Oil filter cutter—custom make by Stan V.
Wing Jacks—works for all models except RV-3

In addition to the Home Wing's tools, certain benevolent members have tools they may be willing to loan. Let the editor know if you have jigs, tools, or shop space to loan, exchange, or otherwise provide.

Tools For Loan		
Item	Owner/lender	Phone / e-mail
Custom cutting wheel mandrel (for cutting your canopy)	Stan VanGrunsven	
Prop tach (calibrate your tach)	Mike McGee	503-534-1219, jmpcrftr@teleport.com
Engine stand	Don Wentz	503-696-7185
Surveyor's transit level (handy way to level wing and fuselage jigs)	Bill Kenny	503-590-8011
Back riveting contraption (large, counterweighted pucking bar and suspension system and offset back rivet sets)	Bob Neuner	503-771-6361
Lead crucible (for melting lead for elevator counterweights)	Doug Stenger	503-324-6993
Table saw taper jig (for tapering wing spar flange strips)	Carl Weston	503-649-8830
48" pan brake located at hanger PLS D-10 at Troutdale if an RV builder needs some metal bent.	Kevin Lane	503-233-1818, n3773@mciworld.com
Aircraft tire bead breaker, for tire removal	Kevin Lane	503-233-1818, n3773@mciworld.com
Special letter drill used to ream rear spar bolts/straight reamer for rear spar/	Kevin Lane	503-233-1818, n3773@mciworld.com
Lasar T-300 magneto timing tool.	Randy Lervold	360-817-9091, randy@rv-8.com
Precision Steel Fuselage Jig for RV-6/6A	Bill Drake	360-687-1698, rv6134WD@uswest.net,
1) Compound lever action lug crimper for battery wires, 2) engine hoist, 3) metal shrinker.	Gary Dunfee	503-631-7262, gary.dunfee@gte.net

Home Wing info:

**A non-profit volunteer organization dedicated to building and flying Van's RV Series Aircraft
Here's the people who do the work:**

Newsletter Editor & E-publisher Randy Lervold 360-817-9091, randy@rv-8.com
 Newsletter Print Publisher Randy Griffin 360-944-7400, skydog-8@attbi.com
 Membership (dues & database)..... Randy Lervold 360-817-9091, randy@rv-8.com
 Meeting Coordinator Randall Henderson 503-297-5045, randallh@attbi.com
 Flying Activities Coordinator Randall Henderson 503-297-5045, randallh@attbi.com
 Annual Fly-in Boss Don Wentz 503-543-2298
 Home Wing web site www.vanshomewing.org
 Webmaster Randall Henderson randallh@attbi.com

IMPORTANT: The Van's Air Force Home Wing newsletter is in no way a publication of Van's Aircraft or any other corporation. All products reviewed or mentioned are not necessarily recommended for use by the Home Wing, but are included for informational purposes only. All building or flying tips represented only the means by which the builder whose name is associated with the tip chose to build or fly his/her aircraft. Builder's tips are not meant to replace the plans and instructions from Van's Aircraft. All information is presented only as a source of information, and this newsletter is a forum for exchange and the sharing of ideas and construction methods only. NO responsibility or liability is assumed, expressed, or implied as to the suitability, accuracy, safety or approval thereof. Any party using the suggestions, ideas, or examples does so at their own risk and discretion and without recourse against anyone. The editor of the Home Wing newsletter and the builder's tips submitters are not responsible for any product, incorrect construction, design failure, unsafe aircraft operation practice, nor any other peril. Any material printed within may not be reprinted without specific permission, and then should include credit to the original source and author. The Home Wing newsletter is published more or less monthly. Subscriptions are \$10/year. Complimentary issue for new builders upon request. Mail or e-mail all subscriptions, ideas, tips, tricks, and articles to the newsletter editor.

Home Wing Membership Sign-up/Renewal

To join or renew, fill out this form and mail to **Randy Lervold, 5228 NW 14th Circle, Camas, WA 98607**, along with \$10 for renewals or new subscriptions. **Please make checks payable to either Randy Lervold or Home Wing.** If you are renewing you only need to give your name, payment method, and any other information that has changed. Please don't forget your e-mail address and newsletter distribution method.

Use this form for address changes too!

Name: _____ Home phone: _____
 Address: _____ Work phone: _____
 City, State, Zip: _____ E-Mail: _____

Project: RV-3 <input type="checkbox"/> RV-4 <input type="checkbox"/> RV-6 <input type="checkbox"/> RV-6A <input type="checkbox"/> RV-7 <input type="checkbox"/> RV-7A <input type="checkbox"/> RV-8 <input type="checkbox"/> RV-8A <input type="checkbox"/> RV-9A <input type="checkbox"/> RV-10A <input type="checkbox"/> (four place)	Status: Not started <input type="checkbox"/> Empennage <input type="checkbox"/> Wings <input type="checkbox"/> Fuselage <input type="checkbox"/> Finish kit <input type="checkbox"/> Flying <input type="checkbox"/>	Newsletter Distribution: E-mail (pdf) <input type="checkbox"/> Mail <input type="checkbox"/> PLEASE check the email box if you have an email address and can possibly accept the N.L. in electronic form. This will ease the burden on the editor and help save money that can be better spent on tools and such.	EAA Chapter: _____ Payment: Check <input type="checkbox"/> Cash <input type="checkbox"/> Info change only <input type="checkbox"/>
--	---	--	--