

HOME WING

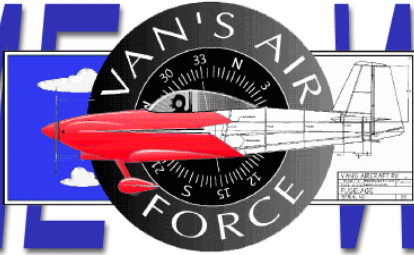

Newsletter of the Home Wing of Van's Air Force — Builders and Fliers of Van's RV Series Aircraft

Annual Member's Directory Issue



The editor's wife Donna enjoys a morning flight to Sunriver. She has a bad habit of hitting the pilot with sharp objects during maneuvers she doesn't like however. Photo by the editor.



Events Calendar

Meeting coordinator:
Randall Henderson
503-297-5045
randallh@attbi.com

MONTHLY MEETING:

(2nd Thursday every month, various locations, 7:00 pm)

Place: Don Wentz's RV-6 rebuild
50641 Firridge Ave., Scappoose, OR
Date: Thursday, March 14th, 2001
Time: 7:00 pm
Phone: 503-543-2298

The March meeting will be at Don Wentz's house, where he will be showing many of the parts and items that he removed from his 600 hr. RV-6 to reduce weight and generally improve serviceability and reliability. Don hopes to share some insights into the things builders need to consider when laying-out their under cowl area. He also has a completely custom baffle and plenum setup that will be interesting to see.

DRIVING DIRECTIONS:

Get on Hwy 30 Northbound (from the Beaverton/Aloha/Hillsboro area take Cornelius Pass). Follow Hwy 30 to Bonneville Drive (approx. 6 mi). Turn left off of the hwy onto Bonneville Drive (Texaco station on right) which is BEFORE you enter the town of Scappoose. There is an immediate stop when you leave Hwy 30. Stop then proceed straight up hill. As you go up the hill, count the streets on the left. The 5th left is Firridge Ave. Go left on Firridge, 50641 is the first house on the right. Big block wall in front, circular driveway, taupe colored house with big porch. It's about a 1/2 hour drive from most areas, traffic should be OK by 7 pm. Please car-pool with your buddies, parking will be a challenge.

Future meeting schedule:

Apr: Bill Drake RV-6
May: Brian Yablon RV-?
June: t.b.d.

Meeting places are always needed: if you'd be interested in hosting a meeting please contact Randall Henderson at 503-297-5045 or randallh@attbi.com

EAA CHAPTER 105 Pancake Breakfast:

First Saturday of every month at Twin Oaks Airpark, 8:00 am, \$5.00 (usually lot's of RVs to look at too!)

This month: 3/2/2002

EAA CHAPTER 105 Monthly Meeting:

Third Thursday of every month at the EAA 105 hangar/clubhouse, Twin Oaks Airpark, 7:00 pm. www.eaa105.org for details

This month: 3/21/2002

EAA CHAPTER 902 Monthly Meeting:

Second Wednesday of every month, Mulino Airport in the OPA building. Info: Bob Boring at 503-661-7627

This month: 3/13/2002

Subscription Due Dates

Mail subscribers: Your renewal date is in the upper right corner of your mailing label. Use the form at the back of this newsletter if there are any changes, otherwise just mail a check to the editor, or pay at a meeting.

E-mail subscribers: Look for your name and renewal date in the e-mail that the newsletter is attached to.

All subscription data is tracked in an Access database. Data entry errors can happen - if you find an error in your renewal date please contact the editor.

Newsletter Delivery

We encourage those still receiving black & white snail mail to switch to e-mail delivery. Some of the benefits include...

- **Faster delivery:** you receive the newsletter 2-3 days ahead of snail mail.
- **Full COLOR:** with the increasing use of photos this adds another dimension you don't want to miss.
- **Storage flexibility:** you can print it on your own printer, or leave it stored electronically, or both.

If you're interested e-mail delivery but unsure, let me send you a test copy. Just send me an e-mail (randy@rv-8.com) and I'll send you a test copy.

Lastly, I would encourage ALL members to make sure I have your e-mail address even if you don't get your newsletter that way. I occasionally send out e-mail to all on important notices and wouldn't want to overlook anyone. Thanks!

...Randy

It's only 1 Pound...

In which we explore some ways to NOT keep adding weight to your RV during the building process.

By The Duck

Chapter 2 Part 2 – More Engine and under the cowl.

One thing I had noticed when working on the plane, removing mags, etc., was that access to the accessory area of the engine was cluttered. So I moved everything on the firewall that I could out to the perimeter, leaving more access directly behind the engine. I moved the right side brake line into the cockpit to get it out of the way, and removed one of my cabin heat inlets. I had done separate inlets with pilot and passenger each having a control. This meant 2 cables and a 4 foot long 2" scat tube snaking across the back of the engine. All of that is now gone, the heat enters the passenger side, immediately 'Y's giving them some heat and a short tube takes some to the pilot's side. It's now much cleaner, less stuff in the way, and less weight.

After 600 hrs my vacuum system had to go. I never used the instruments and they were prone to failure - needing a third rebuild, so out they came (some of this is probably caused by using rebuilt instruments. Pilots of RVs that install new RC Allen gyros don't seem to have failures as often). This also meant the heavy vacuum pump, the firewall-mounted regulator, and the filter and hoses could go, improving cleanliness some more. The Navaid Devices wing leveler will become my gyro backup, an instrument that I'll use much more often. When 'solid state' artificial horizons are more mainstream, I'll look at them.

I had the valve covers, intake tubes, and exhaust brackets Ceramic coated with bright silver, mostly for looks but if it means more heat is carried out of the cowl by the coated pipes, that's a GOOD thing. They did a cool thing where the heat muff goes, putting a coating on the pipe that supposedly 'releases' heat in the muff area. I have no idea if this will have an adverse affect on the longevity of the pipes, guess I'll find-out! Cost of the coating was \$325 total and they look GOOD.

The injection system mounts to the back of the sump (don't ask!) and does a 180 to aim forward. This leaves the heavy injector hanging on the adapters and has always been difficult to support. Nothing I have tried has worked for very long, making this an annoying and unreliable maintenance headache. A friend Jason Ball fabricated a nice brace that also incorporates a good place to locate the mixture cable attach. I took that mix-

ture cable off of Randall's hands. Mine was not real clean in how it connected to the injection. It had never failed, but didn't look great and the routing was weak. Two more difficult but long-needed improvements! While I was at it, I sent the Airflow Performance system back to the factory for a rebuild. It only cost \$250 while for them to do a Bendix is about \$700.

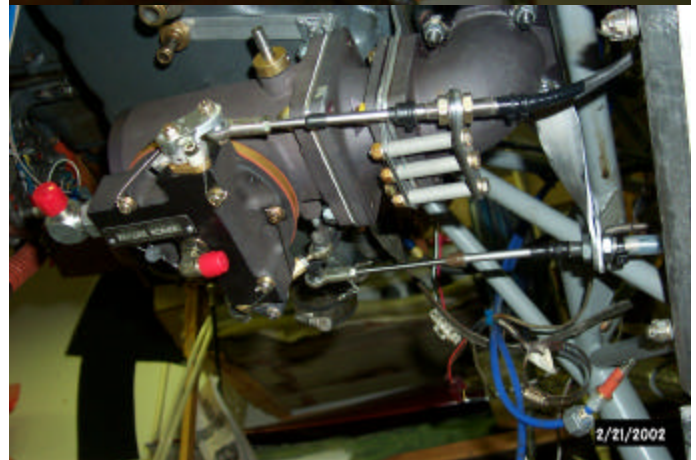

I had all of my fuel pumps and filter located on the firewall inside the hot engine compartment. This led to difficulties in hot conditions and with hot starts. After Dan Benua had such good luck with his installation with the boost pump and filter inside on the floor just in front of the tank selector valve, and seeing the prototype RV-7 with the same location, I decided to move mine there also. This really cleaned the firewall up even more, and puts the minimum amount of fuel line inside the engine compartment. It also moves some weight back towards the CG.

I briefly mentioned the new baffling and plenum in the last chapter. Since that was such a huge project that took over 2 months to complete, I'll show it here. Note the newly molded inlets on the plenum, and the new location of the oil cooler. By using the white plastic I was able to shift the cooler farther from the engine mount



with little loss of inlet area. It also helped to stiffen the area.

Overall I'm very happy with my improvements under the cowl which will make things much more reliable, serviceable, and lighter. Many of the changes were the result of seeing other's installations, and input from others. The custom nature made them take quite a bit of extra time, my baffling and plenum, and injection system are completely one-of-a-kind installations.

To recap all the changes:

1. Replaced Oberg filter with spin-on
2. Reduced overall number and length of oil lines
3. Removed Vacuum system
4. Relocated wires, senders, Voltage Reg, cabin heat
5. Relocated oil cooler to rear of baffling
6. Installed all new baffling including sealed plenum and smaller intakes
7. Improved mount of injection system and mixture control
8. Relocated fuel system to inside cockpit
9. Removed unnecessary heat shielding on cables and wires

One thing I have learned in the years since I first finished my RV-6 is patience. Watching guys like Mike Wilson and Brent Anderson take the time to do different or custom things, and do some of them over again until they are right, has given me the patience to try to do the same thing. Even if I had to scrap the first try or two, or even scrap an idea and do something entirely different, I'm now more willing to do it and the results are pretty rewarding on a personal level.

Next installment – into the cockpit for a foray into the rats-nest behind my panel.

...The Duck

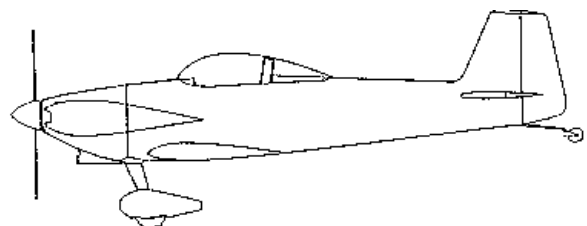

Flying Activities

11th Annual Home Wing Fly-in

Can you believe it, *11 years!* It's official, our 11th annual Fly-in will be on the usual Saturday of Father's day weekend. Format will be the same, come in the morning, have lunch, kick some tires, and head-out in the early afternoon. A small group will be heading for Salmon Arm BC for their Father's Day get together in the early afternoon. Flying Activities Coordinator Randall Henderson will once again coordinate the Salmon Arm event.

One thing we are doing differently this year is giving some of YOU a better opportunity to participate in the planning and execution of our fly-in. To spread the workload a little more, and to insure that these critical functions are adequately staffed, we are implementing a "Team Leader" concept. Each TL will have a specific area of responsibility and will organize volunteers for that area. The 'payoff' will be the satisfaction of having a role in a great Fly-in, and, a free Fly-in T-shirt! We encourage all of you to volunteer for a TL or at least Team Member position. Don't forget that 'many hands make light work'.

These are the tentative Teams:

Team	Leader	Description
Setup/takedown		Includes arriving early to round-up picnic tables on the field. After the event return tables and haul garbage to dumpster.
T-shirts	Mike Wilson	T-shirt design, procurement, and sales. There is much experience here, no need to re-invent the wheel. See Randall Henderson and Dan Benua for quantities and suppliers.
Food	Janet Wentz	Food planning, purchase, setup, and cooking. Randy Griffin, can you bring the bbq again?
Aircraft parking		Aircraft parking, including assisting a/c on and off of taxiways
Auto parking		Auto parking, including keeping driveways clear for emergency vehicles and local airport users.
Ground radio		Directing a/c from the runway to RV or 'other' a/c parking, monitoring Unicom to assist with traffic separation, and reminding pilots to monitor ground once landed. Need to have a handheld radio
Publicity		Get notices placed in appropriate publications, possibly do the mailings to Van's mailing lists.

I will pretty much cover everything else, including notifying all SPB tenants about the Fly-in, working with Port of St Helens, some pre-setup the night before, making my hangar available, assisting the Team Leaders, etc.

We'll have a very short discussion about the Fly-in at every meeting from now to June, so be ready to sign-up or to offer-up any ideas about it then.

...The Duck

Annual Home Wing Member's Directory

Sorted by aircraft type, then last name.

Information is from the Home Wing database as of 2/23/02. Please check your entry. Corrections should be sent to the editor at randy@rv-8.com

Type	Name	St	Phone	E-mail	Status
RV-3	Thibert, Doyle	OR	541-496-0128	thibert@wizzards.net	Wings
RV-4	Adams, Mike	WA	360-892-1299	seaok71302@juno.com	Wings
RV-4	Anderson, Brent	OR	503-646-6380	brenta@pcez.com	Flying
RV-4	Anderson, Alan	WA	360-687-3092	dental-smiles@juno.com	Flying
RV-4	Baker, James	OR	503-854-5900	RVatorN513J@msn.com	Flying
RV-4	Bourgeois, J. Rion	OR	503-646-8763	rion@att.net	FinishKit
RV-4	Corson, Rick	OR	503-201-0057	nosroc@qwest.net	Wings
RV-4	DePute, Larry	AK	907-789-2376	ldepute@gci.net	Flying
RV-4	Dralle, Matt G.	CA	925-447-9886	dralle@matronics.com	FinishKit
RV-4	Elsner, Bernie	WA	509-493-2161		Flying
RV-4	Graham, Gary	OR	503-648-6123	beeb@teleport.com	Flying
RV-4	Harris, Steve	OR	503-647-1989	harriss@esi.com	Flying
RV-4	Hickman, Rob	OR	503-524-3190	robhickman@aol.com	Flying
RV-4	Jackson, Dennis	OR	503-838-4746	denny@tms-usa.com	Flying
RV-4	Lange, Steven	WI	715-355-7755	mmi@dware.net	Flying
RV-4	Leacock, Art	WA	360-687-6821		
RV-4	McGee, Mike	OR	503-534-1219	Mike.McGee@onemain.com	Flying
RV-4	Olender, Henry	CA	650-325-0591		Fuselage
RV-4	Pruner, Chris	OR	541-882-1597		Empennage
RV-4	Reeck, Robert	WA	206-232-3628	lkyswede@aol.com	Flying
RV-4	Weiler, Doug C.	WI	715-386-1239	dougweil@mail.pressenter.com	Flying
RV-4	Wilson, Mike (James)	OR	503-397-6207	james.mike.wilson@intel.com	Flying
RV-6	Asher, M.E. (Mac)	WY	307-654-7717	mcash@silverstar.com	FinishKit
RV-6	Baker, Gary	OH	330-725-3569	ggbaker@zoominternet.net	Wings
RV-6	Barringar, Al	WA	509-773-3150	alsand@gorge.net	Flying
RV-6	Blank, Joe	OR	503-829-6333	jebblank@molalla.net	FinishKit
RV-6	Brabandt, Cal	OR	503-286-5687	calinb@attglobal.net	FinishKit
RV-6	Bryant, Mark	OR	503-266-1844	mark_bryant@cushwake.com	Wings
RV-6	Cannon, Walt	WA		grnlake@earthlink.net	Flying
RV-6	Delveau, James	IA	515-289-2965	jdelveau@fhlbdm.com	Fuselage
RV-6	Drake, William	WA	360-687-1698	drake36@msn.com	Flying
RV-6	Freeman, Brian	OR	503-666-1606		Fuselage
RV-6	Fulgham, Bill	WA	360-571-9974	wrfulgham@cs.com	Fuselage
RV-6	Glass, Roy	AK	907-345-2433	rlglass@alaska.net	FinishKit
RV-6	Henderson, Randall	OR	503-297-5045	randallh@attbi.com	Flying
RV-6	Henderson, George	OR	503-297-0678	GMHSKI@USWest.net	Not started
RV-6	Kenny, Bill	OR	503-590-8011	orazinc@ix.netcom.com	Wings
RV-6	Ketter, Ralph	AZ	480-831-7460	n556rv@juno.com	FinishKit
RV-6	Kimmell, Rodney	OR	503-985-7808	rod.kimmell@att.net	Wings
RV-6	Koch, Frank	OR	503-838-0572	frankandbetty@earthlink.net	Flying
RV-6	Lorz, Terry	OR	503-244-7041	n3722a@uswest.net	Wings
RV-6	McFarland, Bryan	CO	303-567-1176	wbmc@bwn.net	Empennage
RV-6	McMahon, John	TN	615-452-8742	rv6@earthlink.net	Fuselage
RV-6	Moentenich, Brian	OR	503-666-7518	brian.l.moentenich@usace.army	Flying
RV-6	Neuner, Bob	OR	503-771-6361	metalplane@aol.com	Flying
RV-6	Phy, Thomas	OR	541-504-8759	rozy26@worldnet.att.net	Wings

RV-6	Rawllins, Stanley	WA	425-353-4578	rawllins@att.net	Flying
RV-6	Robles, Leejay	OR	503-640-3203	fly.wizard@verizon.net	Wings
RV-6	Russell, Ronald	OR		ron@voyagertravel.com	Empennage
RV-6	Strickfaden, Al	WA	360-687-3119	acstrik@aol.com	Flying
RV-6	Stuhr, Glenn	OR	503-458-6911		
RV-6	Taylor, Bill	CA	530-934-3327		Wings
RV-6	Truax, Bill	WA	360-582-0558	goonybrd@olypen.com	Flying
RV-6	Waldal, Art	WA	360-687-9163	awaldal@aol.com	Fuselage
RV-6	Wentz, Don	OR	503-543-2298	don.wentz@intel.com	Flying
RV-6	Weston, Carl	OR	503-649-8830	carlw@amdocs.com	Wings
RV-6A	Benua, Dan	OR	503-621-3323	danb@synopsys.com	Flying
RV-6A	Billiar, Mike	OR	503-838-2714		FinishKit
RV-6A	Bilodeau, Paul	NJ	732-761-1515	paul.and.ien@att.net	Empennage
RV-6A	Boring, Robert	OR	503-661-7627	carbobbor@aol.com	FinishKit
RV-6A	Burton, David	WA	425-868-7745	dburton@nwlink.com	Wings
RV-6A	Butt, Rob	OR	503-632-7990	N7MZR@aol.com	Empennage
RV-6A	Carlson, David	OR	503-245-8980	davelcarlson@msn.com	FinishKit
RV-6A	Cochran, Jerry	OR	503-925-1517	jerry2dt@aol.com	Wings
RV-6A	Cycon, Michael	AZ	480-838-6353	mike.cycon@honeywell.com	Fuselage
RV-6A	Donaldson, David	OR	503-542-7371	da.donald@verizon.net	
RV-6A	Duberstein, Allen	OR		allen.duberstein@intel.com	Flying
RV-6A	Dunfee, Gary	OR	503-631-7262	garydunfee@earthlink.net	FinishKit
RV-6A	Ensing, Dale	NC	704-243-1129	dwensing@aol.com	FinishKit
RV-6A	Foster, Walt	OR	503-690-3488	wvfoster@earthlink.net	FinishKit
RV-6A	Gleim, Mac	CA	805-238-6407	macgleim@sprintmail.com	Flying
RV-6A	Gold, Andy	CO		winterland@rkymtnhi.com	Flying
RV-6A	Haan, Bob	OR	503-579-2729	bhaan@easystreet.com	FinishKit
RV-6A	Hall, Jerald	OR	503-543-5902	khall@columbia-center.org	FinishKit
RV-6A	Hammell, Pat	OR	503-640-9414	phammell@netzero.com	Empennage
RV-6A	Hoefman, Caspar	WA	615-	choefman@cs.com	Not started
RV-6A	Householder, Steve	OR	503-662-3697	staghollow@aol.com	Fuselage
RV-6A	Hutton, Bill	WA	425-489-1416	bhutton@attglobal.net	Fuselage
RV-6A	Kaluza, Charles	OR	503-638-7820	charleskaluza@sprintmail.com	FinishKit
RV-6A	Kimura, Steve	OR	541-753-9749	steve-kimura@attbi.com	Empennage
RV-6A	Lane, Kevin	OR	503-233-1818	n3773@attbi.com	Flying
RV-6A	Lang, Peter	OR	503-636-4006	langpe@attbi.com	Empennage
RV-6A	Leeman, Larry	OR	503-274-4197		FinishKit
RV-6A	Lund, Chris	OR	503-233-5863	chris@pacificbr.com	Flying
RV-6A	Mays, Virgil	OR	503-543-7697	vetteman@centurytel.net	Wings
RV-6A	McCormick, Gary	OR		garymc@teleport.com	Wings
RV-6A	McCraw, Richard	VT	802-496-5665	rmccraw@wcvt.com	Not started
RV-6A	McDaniels, Scott	OR	503-266-9113	smcdaniels@juno.com	Flying
RV-6A	Miller, Gary	OR	503-524-8269	gmil@poorman-douglas.com	Flying
RV-6A	Miller, Joe	OR	503-647-2059	jwmcmm@aol.com	Empennage
RV-6A	Ohlgren, Brent	OR	503-288-8197	obrento@aracnet.com	Flying
RV-6A	Psiropoulos, Michael	OR	503-681-3088	psirops@easystreet.com	Wings
RV-6A	Psiropoulos, Dean	OR	503-681-0183	deanpsir@ftconnect.com	Fuselage
RV-6A	Rainey, Norm	OR	503-838-3713	NormRainey@aol.com	Flying
RV-6A	Rosenzweig, Charles	WA	360-577-6407	searose@kalama.com	Fuselage
RV-6A	Scott, Richard	OR		rscott@cascadeaccess.com	Empennage
RV-6A	Simpkins, Dave	OR	503-826-9087	DSIMP6125@aol.com	Flying
RV-6A	Smith, Laird	OR	503-648-7449	lairdace@aol.com	Wings

March 2002

RV-6A	Stratman, Paul	MO	816-734-1538	pauls@kc.rr.com	FinishKit
RV-6A	Strong, Gary	MN	783-786-4477	gstrong@qwest.net	Fuselage
RV-6A	Stugart, Jim	TX		DerFlieger@aol.com	Flying
RV-6A	VanGrunsven, Stan	WA	360-254-3492	stanvan@pacifier.com	Flying
RV-6A	Warren, John	WA	360-263-7848	jwdub@teleport.com	FinishKit
RV-6A	Wert, Don	OR	503-757-1781	rvflyboy@attbi.com	Flying
RV-6A	Wessel, Robin	OR	503-639-4365	robin.y.wessel@opbu.xerox.com	Flying
RV-6A	Wotring, Dale	WA	360-887-3196	gusndale@aol.com	FinishKit
RV-6A	Yablon, Brian	OR	503-293-1073	brian.m.yablon@intel.com	Wings
RV-6A	Zander, Dick	WA	360-896-0132	dzan@pacifier.com	Not started
RV-7	Dagan, Amit	OR	503-292-9780	gail.m.rupnick@intel.com	Empennage
RV-7	Lyshaug, Pete	OR	503-246-0452		Wings
RV-7	Moore, Mike	NV	775-782-1224	soarmore@aol.com	Not started
RV-7	Johnson, Paul	OR	503-648-5362	pwjohnson@worldnet.att.net	Empennage
RV-7	Reins, Jeff	WA	360-833-2628	hobjogus@quixnet.net	Not started
RV-7A	Anderson, George	CT	860-669-1093	andrv6a@aol.com	Empennage
RV-7A	Blake, Charles	OR	503-533-7827	charles.l.blake@intel.com	Not started
RV-7A	Boone, Jared	OR	503-466-2877	jboone@earfeast.com	Empennage
RV-7A	Csanky, Laszlo	OR	503-626-4626	drmargit@aol.com	Not started
RV-7A	Greaves, John	CA	530-244-1299	n81JG@aol.com	Empennage
RV-7A	Hauck, Ross	CO	970-209-0468	ross@rossreels.com	Wings
RV-7A	Hopple, Jon	OR	503-642-7928		Not started
RV-7A	Jack, Gordon	BC	250-561-2223	gordjack@telus.net	Wings
RV-7A	Linse, Mike	OR	541-753-3627	linse@ao.com	Not started
RV-7A	Mann, Eric	NV	775-827-0767	freedom@source.net	Not started
RV-7A	Shultz, Tim	OR	503-848-2785	ttshultz@attbi.com	Empennage
RV-7A	Swayze, Bruce	OR	503-775-5544	swayze@europa.com	Not started
RV-8	Belflower, Estol	AK	907-789-2595	ebellflow@gci.net	Empennage
RV-8	Beltrami, Daniel	OR	503-622-6420	daniel_beltrami@hotmail.com	Fuselage
RV-8	Bronson, Tim	PA		zephyrtim@attbi.com	Not started
RV-8	Chambers, Scott	OR	503-656-7019	ghoststone@compuserve.com	Empennage
RV-8	Compton, Scott	VA	540-890-5592	scompton@prodigy.net	Empennage
RV-8	Daubert, Gary	OR		gc.daub@verizon.net	Fuselage
RV-8	Gray, Bruce	NV	775-265-5790		Not started
RV-8	Griffin, Randy	WA	360-944-7400	randy_griffin@hp.com	
RV-8	Griffin, Harry	OR	541-757-8759	hcgrif@peak.org	Not started
RV-8	Imhof, Paul	CA	916-451-6180	paul_imhof@dell.com	Flying
RV-8	Jasinsky, Jeff	WA	360-834-6315	jeff_jasinsky@hp.com	FinishKit
RV-8	Kauffman, Len	OR	503-885-1920	lakauf@aol.com	Wings
RV-8	Lervold, Randy	WA	360-817-9091	randyl@firstaidonly.com	Flying
RV-8	McGowan, Patrick	OR	503-666-0980	p.j.mcgowan@worldnet.att.net	Wings
RV-8	Mensink, Will	WA	509-365-2700	wmensink@ipapilot.org	Fuselage
RV-8	Metschan, Mike	OR	503-466-9458	mmetschan@attbi.com	
RV-8	Mitchell, Jim	OR	503-644-5258		Wings
RV-8	Orr, Scott & Dodi	OR	503-330-3470	aviatorr@hotmail.com	Empennage
RV-8	Paine, Luran	OR	(503) 364-9872	Scan14@msn.com	Wings
RV-8	Porter, John	OR	503-537-9131	december29@peoplepc.com	Empennage
RV-8	Reisdorfer, Mark	IN	812-923-5059	mreisdorfer@ipapilot.org	FinishKit
RV-8	Rice, Dana	OR	503-335-7060	djrice@uswest.net	Empennage
RV-8	Robbins, Mike	WA	425-392-9260	kitfox@gte.net	FinishKit
RV-8	Robertson, Mike	OR	503-681-5337	Mike.T.Robertson@faa.gov	Not started
RV-8	Sutton, Mike	WA	360-944-6618	msutto@attbi.com	Empennage

RV-8A	Andrews, Jim	TX		jnandrew@us.ibm.com	FinishKit
RV-8A	Chiple, Craig	MO	636-332-1529	mechtech81@yahoo.com	Wings
RV-8A	Duncan, Brian	WA	509-375-1118	brian2207@att.net	Empennage
RV-8A	Fogg, Ray	OR	503-538-1661	thefoggs@yahoo.com	Wings
RV-8A	Johansen, Steve	OR	503-363-5695		Flying
RV-8A	Lange, Harmon	OR	503-397-6916	harmon@langair.com	Empennage
RV-8A	VanBladeren, Ron	WA	360-254-1592	rwv@nwnatural.com	Empennage
RV-8A	VanGrunsven, Jerry	OR	503-648-3464	rvforpla@pacifier.com	Flying
RV-9A	Beauchamp, Bruce	WA	360-834-4706	bruceb65@attbi.com	Not started
RV-9A	Byerley, Kent	OR	503-651-3649	byerley@jes.net	Wings
RV-9A	Gerber, Cliff	OR	503-636-3696	cliff.gerber@nike.com	Not started
RV-9A	Gifford, Doug	OR	503-324-0189	dgifford@gte.net	Not started
RV-9A	Grosvenor, Gary	KS	913-393-3531	plncrz@earthlink.net	Not started
RV-9A	Lamb, Frank	OR	503-399-7442		FinishKit
RV-9A	Lattner, Ron	OR	503-324-8703	rlattner@skylab.org	Not started
RV-9A	Lyon, Nelson	OR	503-692-0930	n.lyon@verizon.net	Wings
RV-9A	Mason, Ed	OR	503-288-9275		Empennage
RV-9A	Nicholas, Kim	WA	253-859-1058	knicholas2@aol.com	Fuselage
RV-9A	Park, Gene	OR	503-537-0165	gene@nvaircraft.com	Empennage
RV-9A	Rice, Charles	OR	503-284-1353	crice@tek.com	Not started
RV-9A	Schultheiss, Edward	OR	503-371-3928	edschultheiss@aol.com	Flying
RV-9A	VanGrunsven, Jim	OR	503-	willy@molalla.net	Not started
RV-9A	Woodruff, Brian	OR	503-648-4913	woodruff@dsl-only.net	Not started
Undec	Armbruster, Louis	OR	503-628-2317		Not started
Undec	Bowers, Jeffrey	OR	503-246-2631	jsrewob@hotmail.com	Not started
Undec	Cheney, Dana		503-648-0248	danacheney@aol.com	
Undec	Higgins, Michael	VA	703-207-1645		Not started
Undec	Mandrell, Rick	OR	503-638-8627	rick.mandrell@gte.net	Not started
Undec	Matlack, Dean	AP		dmatlack@cwnetdg.io	Not started
Undec	McHenry, Ted	BC		tedd@vansairforce.org	
Undec	Pugh, Keith	OR	503-774-2380	kpugh@teleport.com	
Undec	Salzman, Sam	WA	360-260-0568	sam@thermalcoatings.com	Not started
Undec	Van's Aircraft,	OR		info@vansaircraft.com	
	Vap, Kevin	KS	913-851-2289	kevin@vap.org	
	Werner, Russ	HI	808-575-2202	russ@maui.net	Fuselage

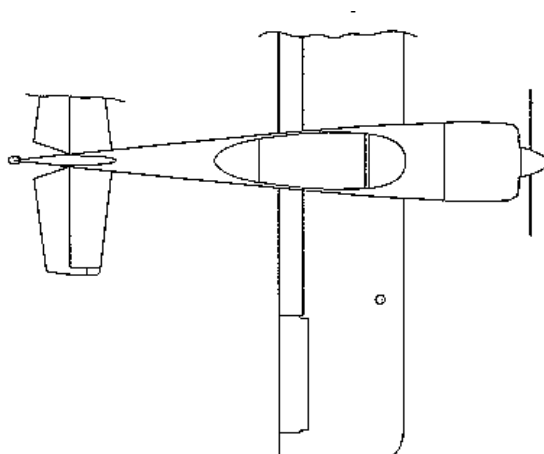

EAA Technical Counselors & Flight Advi-

The following Home Wing members have volunteered as technical counselors under the **EAA Technical Counselor program**:

- **Dan Benua** 503-621-3323 danbenua@mail.com (EAA Ch. 105, RV-6A builder, Hillsboro-Scappoose-Portland area)
- **Jerry Darrah** 503-254-9992 (EAA Ch. 902, A&P, Glastar builder, Portland-Troutdale area)
- **Randall Henderson** 503-297-5045 randallh@home.com (EAA Ch. 105, RV-6 builder, Hillsboro-Portland area)
- **Randy Lervold** 360-817-9091, randy@rv-8.com (EAA Ch. 105, RV-8 builder, Vancouver/Portland area)
- **Dave Lewis, Sr.** 503-690-8237 (EA Ch. 105, multiple RV builder, Hillsboro-Portland area)
- **Brian Moentenich** 503-666-7518, Brian.L.Moentenich@usace.army.mil (EAA Ch. 902, RV-6A builder, Portland-TTD area)
- **Mike Robertson** 503-681-5537 mrobert569@hotmail.com (FAA A&P w/IA, RV-8A builder, Hillsboro-Portland area)
- **Bill Truax** 360-582-0558 goonybrd@olympen.com (Sequim-Port Townsend WA area)
- **Don Wentz** 503-543-2298 jwentz@columbia-center.org (EAA Ch. 105, RV-6 builder, Scappoose-Portland area)



The following Home Wing members have volunteered as flight advisors under the **EAA Flight Advisor program**:

- **Dave Lewis, Sr.** 503-690-8237 (EA Ch. 105, multiple RV builder, Hillsboro-Portland area)



1/1/2002



21 Years of the RV-ator \$27.95
 18-21 Year update pages 16.00
 earlier 18 Year book 12.00

Builder's Bookstore

<http://buildersbooks.com>

PO Box 270 Tabernash, CO 80478
 970 687 2207 970 687 2197 fax

Best sellers for RV Builders

Construction Manuals + Preview Plans

RV-3	\$49.00	RV-7/7A	\$54.00
RV-4	49.00	RV-8/8A	54.00
RV-8/8A	54.00	RV-9A	54.00

RV Construction Videos

Sheet Metal Tools	\$19.50	RV-6 Fuselage	58.00
RV-4 Empennage	41.00	RV-8 Fuselage	48.50
Pre-Punched Emp.	41.00	RV-6/7 Finishing	64.50
RV-4/6 Wings	46.50	RV-8 Finishing	38.50
RV-7/8 Wings	46.50	A/C - Engine Systems	46.50

Airframe Skills

43.13 - Accep. Methods	\$18.95	Aircraft Sheet Metal	\$18.95
Maintenance Handbook	18.95	Corrosion Control	12.95
Sportplane Techniques	24.95	Fiberglass 101 VHS	25.95
Nuts, Bolts, & Fasteners	21.95	Speed With Economy	24.95

Powerplants

Engelis On Engines	\$24.95	Magneto System	\$10.95
Skyranch Manual	19.95	Props & Controls	14.95
Mattuck Overhaul Videos	34.50	Fuel Metering	13.95
Lycoming Operation and Overhaul Manuals see web site			

Electrical / Panel / Finishing

Aeroelectric Connection	\$28.80	AC Painting 101 VHS	\$25.95
Instruments & Avionics	24.95	Painting & Finishing	13.95
Avionics Troubleshooting	32.95	Custom Interiors	19.95

CLASSIFIEDS...

Classifieds are free to Home Wing members. Ads will run for three months. Send to editor by e-mail or mail. Renewals ok, just let editor know. Date at end of the ad is last month ad scheduled to run.

FOR SALE

RV-6A partially finished — O-360 mounted with C/S prop. VFR panel with stereo. Fuselage, wings, canopy and cowling done. You pick the upholstery and paint. Some tools also available. Divorce forces sale! \$49+K invested/sell for \$46K OBO Call: Terry @ 503-680-2104 Kevin @ 503-789-1529 Ace@pnnw.net, 5/02

Mitchell Analog 2 1/4" Aircraft Clock — Has Hours/Mins/Secs plus 2 set-able markers. Works great but needs new adjustment knob - \$10. Don Wentz - jwentz@columbia-center.org - 503-543-2298 2/02

AComm model AC-4 Intercom - 4-place portable with record in/out, PTT, etc. Don't know if it is stereo or not. Don Wentz - jwentz@columbia-center.org - 503-543-2298, 03/02

4-WAY CHT/EGT SWITCH — Electronics International RS-4 switch. No sensors, switch & faceplate only, \$40, Randy Lervold 360-901-2150, randy@rv-8.com 4/02

Andair Gascolator — Mounted but never used. Will include firewall bracket. \$100, Mike Robbins, 425-392-9260 kitfox@gte.net, 3/02

Whelen A490 ATS DF Strobe Power Supplies—I have two of them. They work on 14-28 volts. \$240 plus shipping from Eugene. Wally Anderson 541 683 2328, wallyander@earthlink.net, 5/02

Firewall forward: '0' time O-360 A1C engine, New '0' case, new Hartzell Prop HC-C2YK-1AF hub, Blades s/n D-79637/D-79581, prop extender, spinner, exhaust, all accessories. Engine ran 1 hour on a Thorpe before removing to sell separately. \$12,000. Del Zander 503-620-1335, 6/02

UPHOLSTERY HIDE LEATHER — A DEAL YOU CAN'T PASS-UP! 1 remaining hide of gray top quality Andrew Muirhead fine Scottish leather for upholstering your RV seats. Approximately 50 square feet in size. \$250 which is half of the normal retail cost. Contact Judy Vangrunsven for details, 503-648-3464, 03/02

Duckworks Landing Lights - Retro-fittable, light, easy installation. Kits start at \$69, discount for Home Wing-ers. Don Wentz, 503-696-7185

EAA CHAPTER 902 is selling Air Force A-2 leather jackets to raise money for it's hanger & educational building fund. Sizes range from XS to 3XL in Dark Brown or Black. Only \$98 (tall sizes \$108) and you help your EAA chapter. Order now for the winter, Christmas, or for a friends gift. Contact Gary Dunfee 503-631-7262 garydunfee@earthlink.net or Jim Wasson 503-655-3301. We'll also take donations for the hanger fund and give you a receipt for tax purposes. 2/02



WANTED

Parts Wanted — I'm finishing up an abused RV-4, I need vfr flight instruments and engine instruments for an O-320. Also, engine baffles, exhaust, carb, prop and spacer. Mark, 719-276-3034, pawnee235@yahoo.com, 6/02

Partner For RV-4 — Seeking partner to purchase flying RV-4 with. I am a fairly low time pilot and have found an RV 4 locally that is not IFR equipped that is to be for sale for \$48K. I believe this to be a sound unit and am looking for a partner to buy it. Ed Barrow ebarrow@casgen.com, 6/02

WANTED: Women pilots, to give Young Eagle Rides to girls in the AWSEM Program. Please call: Marcy Lange @ 503-397-6916 or e-mail: marcy@langair.com, 6/02

Use 'em!

Members are encouraged to take advantage of the classified section. Since it's free why not take a stab at unloading that unused airplane stuff. Besides, it's kind of interesting to look at all the odds 'n ends for sale.

Please note that the date at the end of each ad is the expiration date. They run for three months and then are dropped unless you want them renewed by notifying me.

...Randy

THE TOOL EXCHANGE

The Home Wing owns a selection of tools for use by its members. The Toolmeister is: **Brent Ohlgren, 503-288-8197, obrento@aracnet.com**. Please observe our Tool Policy:

Home Wing Tool Policy

- Everything goes through Brent — do not give the tool to another member.
- Brent will keep an accurate sign-out sheet for each item so he knows where it is at all times.
- Brent will inspect all tools upon their return. If there is any damage he will ask you to pay for the repair (with the threat of public humiliation if you fail to be a grown-up).

The ability to have use of these expensive tools is a real membership benefit, let's respect the group's assets.

Home Wing Tools

HVLP paint sprayer, turbine type. Includes gun and air turbine.

Hole template for instrument panel.

Wire crimping tool & die large gauge wires (e.g. battery leads)

Brake lining rivet set.

Tune-up & annual kit (compression checker, mag timing light, timing dial, mag adjustment tool, plug gapper, high voltage cable tester, and plug vibrator cleaner.

Aircraft scales — allows you to accurately weigh your beast and also determine CG.

Oil filter cutter—custom make by Stan V.

Wing Jacks—works for all models except RV-3

In addition to the Home Wing's tools, certain benevolent members have tools they may be willing to loan. Let the editor know if you have jigs, tools, or shop space to loan, exchange, or otherwise provide.

Tools For Loan

Item	Owner/lender	Phone / e-mail
Custom cutting wheel mandrel (for cutting your canopy)	Stan VanGrunsven	
Prop tach (calibrate your tach)	Mike McGee	503-534-1219, jmpcrftr@teleport.com
Engine stand	Don Wentz	503-696-7185
Surveyor's transit level (handy way to level wing and fuselage jigs)	Bill Kenny	503-590-8011
Back riveting contraption (large, counterweighted bucking bar and suspension system and offset back rivet sets)	Bob Neuner	503-771-6361
Lead crucible (for melting lead for elevator counterweights)	Doug Stenger	503-324-6993
Table saw taper jig (for tapering wing spar flange strips)	Carl Weston	503-649-8830
48" pan brake located at hanger PLS D-10 at Troutdale if an RV builder needs some metal bent.	Kevin Lane	503-233-1818, n3773@mciworld.com
Aircraft tire bead breaker, for tire removal	Kevin Lane	503-233-1818, n3773@mciworld.com
Special letter drill used to ream rear spar bolts/straight reamer for rear spar/	Kevin Lane	503-233-1818, n3773@mciworld.com
Lasar T-300 magneto timing tool.	Randy Lervold	360-817-9091, randy@rv-8.com
Precision Steel Fuselage Jig for RV-6/6A	Bill Drake	360-687-1698, rv6134WD@uswest.net,
1) Compound lever action lug crimper for battery wires, 2) engine hoist, 3) metal shrinker.	Gary Dunfee	503-631-7262, gary.dunfee@gte.net

