

**The Newsletter of the Portland RVators; Builders and Fliers of Van's RV Series Aircraft**

**December Meeting**

The December meeting was held at Charlie Kaluza's shop, where he is working on his RV-6 fuselage. The envy factor was high as 40 of us fit comfortably in his spacious shop, warmed by a wood stove in the corner, well lit by fluorescent lights in the ceiling, and not crowded at all, even sharing space with an RV-6 fuselage in the jig.

Frank Justice held forth on techniques and "gotchas" at this stage of the project, including how to make sure all the bulkheads line up, places where the plans may be a little bit off (and where you're likely to *think* they're off but they're not), and how to bend the longerons. This last topic helped to de-mystify this part of the project for many of us. Frank has written up a "short course" in fuselage construction which I've included in this newsletter.

Don Wentz also contributed some tips on the fuselage as well as on the subject of wing wiring -- mostly how NOT to do it the way he did. Don also mentioned a possible trouble area which has shown up in his plane and others, involving rivets that hold the belly skin on. Both of these themes are also expanded upon in the builder's tips section.

<b><u>Meeting Notice</u></b>
Place: Frank Justice's Place 9725 SW 163rd Ave., Beaverton
Date: January 12 (Thursday)
Time: 7:00 pm

The next meeting of the RV Builder's Group will be held at Frank Justice's house on Thursday January 12 starting at 7:00 PM. The address is 9725 SW 163rd Ave, Beaverton, which is in the Bishop's Ridge subdivision on the eastern end of Cooper Mountain near the top. Phone number is 590-3991 if you get lost.

Directions: Turn west on Weir Road off of Murray Blvd. (just a few blocks north of Scholl's Ferry Road intersection). Go almost to the top of the hill and turn right

on 160th. Go to 163rd Ave and turn left. Go up the hill to where you see a Victorian-style five-globe light post out front.

I apologize for the fact that this project looks so much like the last one (an RV-6A fuselage only a month or so ahead of the one you saw last month) but I couldn't find anyone who was doing an empennage and was willing to host the meeting. I will be twisting arms at this one. We have a lot of new builders in the area, most of whom are worried about things like how to set up their shop and scared to drill the first hole. Remember? We need someone to host who is in the middle of either their horizontal or vertical stabilizers in order to give a boost to all the new builders and wanna-builders in the area.

Also, I found that our group phone list is seriously out of date. Please look at the information in the one that was sent with last month's newsletter and give me or Randall any updates.

As usual, bring in any tools, fixtures, whatever that you are willing to loan out, pass on, or are ready to return to the owner. - *Frank Justice, Meeting Coordinator*

**General Business**

**Didn't get your newsletter?**

Several people told me they didn't get their copy of last month's newsletter, and of those who did some said it was "badly mangled", as if it got caught in a sorting machine at the post office. If you didn't get yours yet, drop me a line or give me a call and I'll send another, or pick one up at the meeting -- I'll be sure to bring some along.

**Top Ten List**

The holidays always bring with them plenty of relatives and friends that I haven't seen in a while, and inevitably the discussion comes around to my RV project. I enjoy talking about it to the un-initiated, but part of me has begun to dread it. The reason can probably best be summarized in my

**Top Ten Questions I'm Tired of Being Asked by Non-RV Builders:**

- 10. When is it going to be finished?
- 9. Don't they make those over in Redmond?
- 8. You're building a motor home?
- 7. What's the difference between this and a *real* airplane?
- 6. Aren't you scared of going up in something you built yourself?
- 5. No really, when are you going to be finished?
- 4. That uses a Volkswagen engine, right?
- 3. You're building an airplane? Hey, did you read about that airplane that crashed last week?
- 2. Come on, you must have *some* idea when you're going to be finished.
- 1. Neat. Where's the rest of it?

**Calendars**

I still have copies of Van's 1995 calendar -- \$6 each (special builder's group member discount!) This is a good calendar, and you will probably recognize at least ONE plane in there -- our own Ken Scott's RV-6.

**T-Shirts, Patches, Decals**

I still have some T-Shirts left, long and short sleeve, in small, medium, large and XX large. Sorry, no extra larges or sweatshirts left. I'll have 'em at the meeting.

I asked for a show of hands at the December meeting to get an idea of how many people would be interested in a "Portland RVators" patch or Decal, and around half of the people present raised their hands for both items. I've checked into this and found a place that makes high quality, all weather decals -- but the catch is at low quantities the price goes way up. This means I'll probably have to charge a fair bit over cost unless I get orders for at least 100 of each. Would you be willing to pay \$12 to \$15 for a 12" "Portland RVators" decal? How about \$10 to \$12 for a patch? Give me a call or let me know somehow. The more people who sign up, the less they will cost.

And speaking of the logo, I was talking with Van and Bill the other day and they told me that they were interested in adopting it, with *Van's Air Force* instead of *Portland RVators* around the circle, as a unified logo for the world wide RV "fleet". I had some reservations about letting that particular logo go, since it would mean giving up some of the uniqueness of our group's identity, but after talking with several other members in the group and finding no real resistance to the idea, I decided to go ahead and do it. So don't be surprised if you start seeing "Van's Air Force" T-Shirts, hats, etc. with something on it that looks suspiciously like the *Portland RVators* logo.

**Subscriptions Due:**

Look at the date under your address on the cover. **THAT IS THE DATE YOUR \$8 IS DUE.** Mail to me (**Randall**) or give it to me at the next meeting (my address is the return address on the cover). If you are paid up but the date doesn't reflect this, please give me a call so I can correct it. I'm still working out the bookkeeping on this deal, so bear with me!



**EVENTS CALENDAR**

**EAA Chapter 105 Meeting** Thursday January 19, (third Thursday of every month), 7pm at Twin Oaks Airpark. Good programs, don't miss em. Last month was the Christmas Potluck -- good food, good hangar flying!

**EAA Chapter 105 Pancake Breakfast** - Saturday February 4th, (first Saturday of every month) at Twin Oaks Airpark, 8am.

January's breakfast did not have as big a turnout as in past months; only 40-50 diners. But the RVs were there in force! Dick VanGrunsven flew in in the factory RV-6B, Jerry and Judy VanGrunsven flew in in their RV-4, and Ken Scott showed up in his RV-6. Bill Benedict flew *out* in his RV-4 after breakfast, with Randall in the back seat. Jerry and Linda Springer showed up late and pulled up to the pumps for gas, but didn't even come up for a cup of coffee ☺. Rion suggested we put sign on the pumps: 'Free coffee with fill-up'. "When they come up and smell the grits, they'll no doubt spring for a breakfast!"



**A Short Course on Starting Your RV-6**

**Fuselage**

*Frank Justice*

You are now beginning the really fun part of RV building (at least if you have finished the firewall). By now you do not get the shakes whenever you start to drill the first hole in a new assembly, and it's beginning to feel like a real airplane. The construction manual has lots of details about building the bulkheads but is a little sparse when it comes to describing how to start tying everything together. Hence this short course to get you going.

To begin with, you should do everything you can at as early a stage as possible. This means doing everything you can to all the bulkheads even before you jig it up. On the firewall, rivet everything together, except do not rivet on the prop governor/oil filter clearance box yet. On the F-604 bulkhead (where the main spar goes) do not rivet the side pieces to the uprights but do rivet the rear uprights to the crosspiece. Rivet everything you can on the F-605 bulkhead, then shape the F-657 top gusset but do not drill it to the bulkhead yet. Just note that sliding canopy builders can leave out some parts

and that some latch components must bolt on later at the top corners for the tip-up. On the F-606 baggage compartment rear bulkhead, build it completely and also the F-628 and F-629 ribs, but do not rivet them on yet. Drill the bolt hole in the ribs for the elevator bell-crank also. Make sure the basic structure of the bulkhead is the right height before drilling the F-628 rib to it. By the way, the two outboard baggage ribs are a little too tall; use the center ribs instead to locate the baggage floor support angle.

The construction manual implies that you should bend the main longerons and then attach all the bulkheads to the jig at this point, but it is a little easier to use the following order because things are better supported.

Bolt the firewall and the rear bulkhead to the jig. Bend the longerons, clamp them to the jig at the F-604 position, and drill them to the firewall. Attach the F-604 bulkhead to the longerons using the F-604E channels. Clamp the F-605 bulkhead to the jig and the longerons with the F-657 gussets in position.

Clamp a couple of strips of something between the firewall and the F-604 bulkhead (note that this bulkhead is not quite vertical) to hold them properly spaced, then make all of the angles, gussets and ribs that go in between. Note that the RV-6 uses several small gussets and the RV-6A uses one large gusset here. Also make the four floor stiffeners and the rudder pedal mounts at this time. For the -6A, notch the bottom longerons to clear the landing gear mounts. Then put in the seat ribs, making sure the F-605 bulkhead to F-604 bulkhead distance is just right for the wing main spar and rear spar to fit in them. Add the side ribs in this area too. Then do the baggage compartment floor ribs, side ribs, and finally the F-649 and F-650 baggage side pieces. Because the outer baggage ribs are too tall they won't fit properly if placed as shown on the plans; moving them inboard a little bit will fix this. Also, you will likely need to modify the baggage rib end flanges to get the right angle and also the right rib length so the F-606 will be vertical.

You now have F-606 thoroughly secured. Add the rest of the bulkheads except the next to last one to the jig, making sure they are the proper distance from the firewall and the proper height above the main longeron. The bulkheads will probably be very close to the right overall height and width, but the slots for the main longerons may not be in quite the right place. Attach about 6 strings pulled tight between F-606 and the rear bulkhead. If you didn't make any measurement mistakes the bulkhead sides and bottoms (tops as you are looking at them now) should come fairly close to the string lines.

The F-607 and F608 bulkheads are intentionally made about 1/4" too wide to line up with the rest; this is supposed to make the skin look better. Get the bulkheads lined up as close as you can on the sides while keeping them vertical. There will probably be just a bit of misalignment left in the bulkhead tops; eliminate this

by tilting the bulkhead forward or backward. Tape the bulkheads to the strings to hold them.

Now, fit the rest of the longerons on, add the F-628 rib, then fit the next to last bulkhead. Rip it all apart, clean it and prime it, add all the nut plates, rivet it all back together including the center rudder pedal support bracket and then the firewall cutout box, and you are ready to skin this beast.

For that, drill #50 holes in the skeleton first, then put a skin on, back drill it #50, then do the final #40 or #41 drilling in the proper order from the outside. The skin will shift slightly as you do the final drilling and cleco-ing, hence the initial #50 drilling.

*The detailed instructions for this part of the project are now available for checkout if anyone would like to volunteer. It takes 18 pages to cover the above procedures in detail. Call Frank Justice at 503-629-7808 or 590-3991; frank@ssd.intel.com.*



## Effects of Weight on RV Speed

John Henderson

There has been some discussion lately on the RV mailing list on the Internet about the effect of weight on speed. Some have argued that the weight of a constant speed propeller would decrease speed. Others have said that they've noticed a 5--10 mph decrease in speed when carrying a passenger. Is this all possible? I decided to calculate some numbers and see.

The drag on an aircraft is composed of two parts, the parasitic drag, which we will designate as  $D_p$  and the induced drag,  $D_i$ . The parasitic drag is simply the force required to push the aircraft through the air due to the friction between the aircraft and the air. Mathematically, the parasitic drag can be expressed as

$$D_p = \frac{1}{2} \rho V^2 f$$

where  $\rho$ , the Greek letter rho, is the density of the air, which, in the English system, has the strange units of slugs per feet cubed,  $V$  is the velocity, in feet per second, and  $f$  is the flat plate area in feet squared. The flat plate area is an easy way to express the aerodynamic cleanliness of a design. It is the area of a flat plate that would require the same force to push through the air at a given speed as the aircraft would require. The flat plate area is not necessarily directly related to the size of the aircraft as a larger, but cleaner, aircraft may have a smaller flat plate area than a smaller, less aerodynamic, aircraft.

The induced drag represents the force required in making the wingtip vortices. There are ways to reduce the vortices, but not to eliminate them entirely. The induced drag is

$$D_i = \frac{kW^2}{\frac{1}{2}\rho V^2 b^2}$$

where  $k$  is a unitless planform coefficient,  $b$  is the wingspan in feet, and  $W$  is the weight of the aircraft in pounds. The constant  $k$  is dependent upon the plan shape of the wing, and because it is in the numerator of the equation, the larger  $k$  is, the more induced drag there will be. The most efficient planform is the elliptical wing, with a  $k$  of 0.3183. All other planforms have higher  $k$ . Also notice that weight is in the numerator, so induced drag increases with weight. This is where higher weight predominantly contributes to slower speed.

The total drag is equal to the induced drag plus the parasitic drag. If we denote total drag as  $D_t$ , then  $D_t = D_i + D_p$ . Note that the induced drag has the velocity in the denominator while the parasitic drag has it in the numerator. If we were to plot these two components of the drag versus speed, as in figure 1, we would see that the induced drag decreases with increasing speed, while parasitic drag increases with increasing speed. Adding the two together results in the bowl-shaped graph in figure 1.

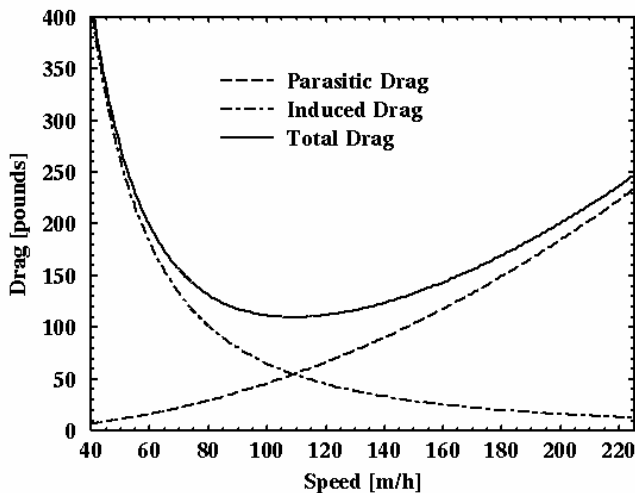

Figure 1: Typical plot of induced drag, parasitic drag and total drag for an RV-6

To maintain a certain speed, the aircraft must generate a thrust equal to drag at that speed. However, for reciprocating-engine aircraft, horsepower is more natural unit of expressing the intensity of motivation. Horsepower, though, is a measure of power, and not force, so we cannot directly equate the drag to the power. Power is basically the force times the speed at which we can deliver that force. So, the thrust horsepower required to overcome the drag at a certain speed is the drag times the speed, so  $thp = D_t V$ . The thrust horsepower, however (seems to be a lot of "however's"), is the power usable for driving the plane through the air, and is not equal to the power delivered by the engine to the propeller shaft. This is because some of the power is lost overcoming the drag of the propeller blades moving through the air. A blade efficiency  $\eta$ , the Greek letter eta, is defined which relates the power

generated by the engine, the brake horsepower, to the thrust horsepower by  $thp = \eta bhp$ . This coefficient is always less than one and typically is no larger than 0.8. For a given prop pitch, this efficiency factor peaks at a certain ratio of propeller rotational speed to aircraft forward speed. With a constant speed prop, we can effectively vary the pitch of the prop so that we operate near maximum efficiency most of the time. For a fixed prop, we can only reach this maximum efficiency at certain combinations of airspeed and RPMs.

My goal is to find all of the numbers behind this alphabet soup to allow me to predict the power required to drive an RV-6 through the air at a given speed. I will make some engineering approximations (educated guesses) for some of the parameters, and get others through experimental data.

My first approximation is for the propeller efficiency. An  $\eta$  of 0.8 is a typical maximum value so I will use this throughout the speed range, even though this would only be valid for a CS prop. However, I am ultimately trying to find the effect of weight at typical cruise speeds, where the properly chosen prop will hopefully be running near peak efficiency. With these assumptions, I can write an equation for the required brake horsepower as a function of speed:

$$bhp = \frac{V}{\eta} \left( \frac{1}{2} \rho V^2 f + \frac{kW^2}{\frac{1}{2} \rho V^2 b^2} \right)$$

I still need to know the values of the other variables. The wingspan  $b$  is 23 feet. I am assuming a weight of 1320 pounds which consists of a 1000 pound plane, 20 gallons of fuel, and a medium-sized, 200 pound pilot (Let's be serious here--I've seen us at fly-ins). The planform coefficient  $k$  for the rectangular wing is 0.3483 (Thanks to Dr. Cutchins and Dr. Burkhalter in the Auburn Aerospace Engineering department for help with this.) I will use data from Van's promotional brochure to determine the other variables. Speed data for an RV-6 is given at 8000 feet density altitude as 192 mph at 75% power, and 170 mph at 55% power. I look in a table and see that that 8000 feet corresponds to an air density  $\rho$  of 0.001869 slugs per feet cubed. I now put this equation in a program called MATLAB and plot the brake horsepower required versus speed, trying different  $f$  until I get the plot to fit the data provided by Van's. You can use different programs to do the same thing, such as a spreadsheet program. An  $f$  of 2.3 feet squared gives an excellent match. It is interesting to note that the flat plate area of 2.3 is less than that of a Mooney 201 with a flat plate area of 2.81, which is one of the more efficient factory designs.

Knowing all of the variables, I made a plot of the required brake horsepower versus speed as shown in figure 2. To see the effect of adding a passenger on speed, I added 200 pounds to the weight, for a total of 1520 pounds, and drew another curve for this weight. If we look at the horizontal distance between the two curves at a given power setting, we can see the speed

loss at that power setting. For example, at 75% power, at 1320 pounds we had a speed of 191.2 mph. If we draw a line to the left, it will cross the 1520 pound curve at about 189.2 mph, for a loss of about 2 mph. This is not quite the 5--10 mph loss that some have reported, but considering use of a fixed-pitch prop, and considering approximations in the equations, the lower end of this range may be reasonable, although I may question a loss of as much as 10 mph. Only careful testing, taking air density and wind into account, could verify these claims. Will the addition of 50 lb. for a CS prop significantly decrease performance? If adding 200 pounds only results in a 2 mph decrease, the speed loss when adding 50 pounds would be a fraction of 1 mph, which would more than likely be made up for by the increased efficiency of the CS prop. Note, however, that climb performance is typically impacted more severely by increased weight than speed.

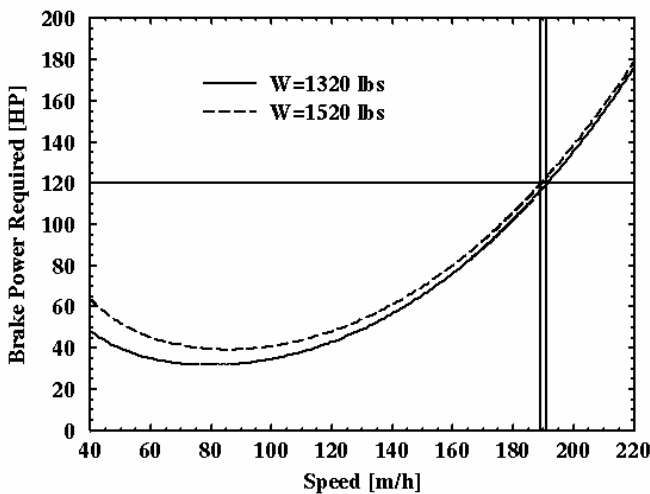

Figure 2: Plot of brake horsepower required versus speed for an RV-6 at weights of 1320 pounds and 1520 pounds

While we're plotting power-speed curves, we can investigate another idea. Some have hoped that Van would develop a more efficient wing, such as a tapered one, which has a  $k$  somewhere between the elliptical planform and the RV's rectangular planform. If I plot the power-speed curve for the RV-6 again, and plot the curve for an RV-6 with an elliptical wing of the same span, as in figure 3, I show virtually no difference at cruise speed.

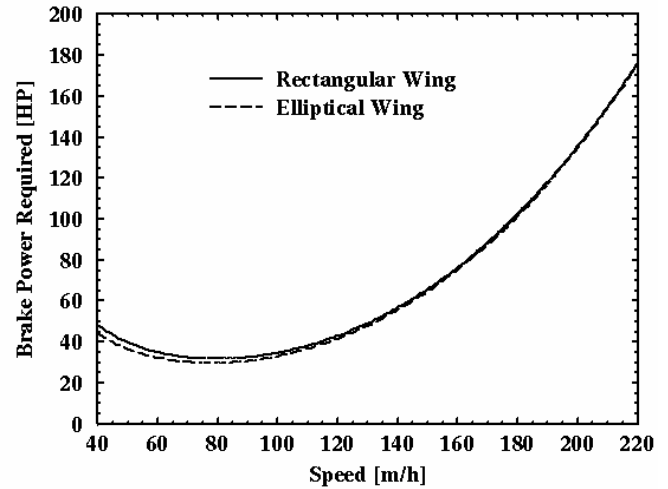

Figure 3: Plot of Brake horsepower required versus speed for an RV-6 with rectangular and elliptical wings

The first advantage of the rectangular wing is its ease of construction. Also, the rectangular wing naturally stalls at the root first, with the stall progressing outward. This results in a softer stall, and maintains control by keeping the ailerons out of the stall. It would appear that Van knew what he was doing (not that I doubted him).

Most of the information I got to make these calculations came from the book *An Illustrated Guide to Aerodynamics*, 2nd Ed., by H. C. "Skip" Smith, TAB Books, copyright 1992, ISBN 0-8306-3901-2. I recommend it highly for any pilot or homebuilder who does not already have an aerospace engineering degree.

*John Henderson comes to us by way of the internet (john@eng.auburn.edu), and visited several of us here in the Northwest when he was in the area. He has a masters degree in Electrical Engineering, has done work for the Department of Defense, and is currently working on stealth technology for NASA as part of his Ph.D. research. Even so, he still says "my greatest claim to fame is that I installed the Com antenna on N790DW" (Don Wentz's RV-6).*



## Interviews with an RV Builder

By Bob Neuner

**Name:** Dick Zander

**Occupation:** Retired Meteorologist

**Pilot Ratings:** SEL, Multiengine, Sea

**Aircraft Building Experience:** Took A&E course at Parks College of St. Louis University. Has worked in all media except Wood & Fabric. (Good thing he's building an RV!)

**Project:** RV6A Plans number 21788

**Engine/Prop:** None chosen, is considering NEW engine.

**Project Status:** Tail Complete, Wings in the Jig. Building both at once. Leading Edge finished, Duckworks lights installed.

**Workshop:** Double car garage.

**Special Tools:** Stan VanGrunsvan's drill bits modified for drilling plastic. Plans to back rivet wing skins.

**Profile:** Dick just turned 70 in September. He is a former Bonanza Owner who has 75 hrs. in Stearmans. He also has time in J3's, J2's, BT13 "Vibrators", SNJ's, the PBY, PBM, and the Navy PB4Y2 "Liberator". Dick's Tail dragger experience also includes time in a SNB, the military's version of the Twin Beech. This plane is a real "ground looper" by Dick's account. The RV6A should be a breeze for him to land.

Dick set up both wings back to back in the jig, something I wish I had room to do. He also came up with a clever technique of installing the lens for his landing lights. Rather than using straps to pull the lens tight against the leading edge skin, he carefully measured and cut a 2X4 to the depth of the leading edge (LE). He padded the end with foam, fit the lens on over the top, then set the LE structure over it. The foam holds the Plexiglas tight to the skin for drilling. Easier for the builder working alone.

If you have a chance talk to Dick Zander during one of our meetings, don't miss it. He's got a lot of fascinating stories from his years as a pilot and as a Meteorologist.



**Builder's Tips** *Thanks to all who share them with us!*

**Fuselage floor to Firewall loose rivet problem on RV-6/6A**

During my winter down time I noticed that most of the rivets attaching the .040 fuselage floor to the 1/8" firewall angle have cracked paint around them. There are also a few on the .062 stiffener angles that run the length of the floor.

These rivets are all 3/32" and machine countersunk into the skin. I have asked around and found this to be a fairly common problem. Several local -6s have had it, and some A&Ps have reported finding it at annuals. I now need to fix this on my -6, and would recommend that a different method be used than what I used in the first place. My 'personal opinion' is that 3/32 rivets in material that thick at that location are not adequate.

My recommendation (you can/should evaluate this recommendation based-on your own skills that will be well developed by the time you get to that point in your project) is as follows:

For NEW construction, use 1/8 rather than 3/32 rivets on the skin/firewall, 3/32 on the stiffeners, but dimple the skin and machine countersink the 'angles' rather than machine countersinking the skins.

For completed a/c, there are options:

1) drill-out and replace failing rivets with 1/8 universal head rivets. This has been done and seems to be a successful fix.

or

2) drill-out and replace failing rivets with 3/32 rivets, and add another matching rivet in-between where possible, to increase the total rivet count.

or

3) drill-out and replace failing rivets with "oops" (1/8 shank, 3/32 head - NAS1097AD4-6) rivets, and add another matching rivet in-between where possible, to increase the total rivet count and the amount of rivet 'shank' at the skin to angle surface.

I plan to use option 3 to repair my RV-6.

Note that these are ONLY my opinions. Neither these 'fixes' NOR the fact that a change is required are necessarily recognized by Van's. The fact that I had a problem here is the main reason I am recommending that you evaluate the situation and MAKE YOUR OWN DECISION. My own workmanship/riveting skills may have contributed to the rivet failures, but there are many others experiencing the problem, so I felt a need to mention it. - Don Wentz

**Wing Wiring -- Where to Put It?**

One of the decisions you have to make when building the wings is how and where to run the wing wiring (if any). Basically, the choices are whether or not to use some type of conduit, and if so, what type and where to run it.

Most RVs I've seen that have wingtip nav lights and leading edge landing lights use some sort of conduit, and this seems prudent, both to protect from chafing, and for ease of installation and possible replacement or addition of wires. If you decide to go with conduit, the next question is where to run it, and what type to use? If you run the conduit ahead of the spar, you'll need to use flexible tubing. Aft of the spar you can use either flexible or rigid.

Frank Justice used 1/2" CPVC, 2 1/4" aft of the spar flange and 1 1/4" from the top skin. This method has the advantage of providing a straight, rigid tube to push or pull wires through, and is simple to install -- just make a template to mark and pre-drill all the ribs in the same spot, then shove the conduit in sometime before final skinning, and secure in place with some dabs of caulk or RTV. The main disadvantage is that your wiring enters the cockpit aft of the spar, and you have to route the wires through or around the spar and center section bulkhead. This isn't as big a problem if you're going to have a center console, however. (Or for that matter, an RV-3 or -4.)

I chose to run my wiring conduit forward of the spar to avoid the problem of getting around it. This method involves a little more work, and necessitates using some sort of flexible tubing since you have to run it

right against the spar where it goes behind the fuel tank (fastened to the spar doubler with line clamps or bent pieces of aluminum), then bend it a bit to get through the rib reinforcing angles at the inboard leading edge ribs. I used 1/2" O.D. polyethylene tubing (from Falk Hardware). Van's also has a very light flexible conduit that can be used for this purpose. In the two inboard leading edge ribs I drilled a hole for the tubing through the center of the rib reinforcing angles, and through the web just forward of the angles in the rest of the ribs.

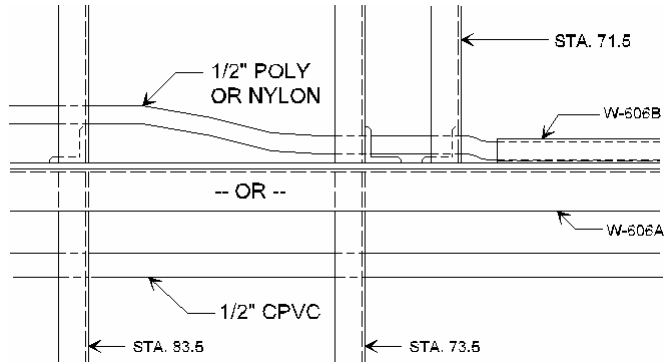

- Randall Henderson

**Even the smallest things can make a difference...**

What color pen do you use to mark your rib centerlines for drilling? I've found that a red pen is much easier to see through those little holes than is blue or black, especially on un-primed ribs. It may seem ridiculously simple, but I know of at least one instance where a guy wandered awfully close to the web simply because he couldn't see the lines he'd drawn on his fuel tank ribs with a black sharpie pen. - Randall Henderson

**Patching Holes in Aluminum**

At one time or another some of us builders have drilled extra holes in aluminum parts. Most of the time it's no problem because it is inside the airframe. Sometimes it is in the skin and can be easily patched with a rivet.

There are times however, when using a rivet to fill an extra hole in the skin won't work or is undesirable.

I put a couple of extra #40 holes in the trailing edge of my RV-6 wing top skins where the inboard piece overlaps with the outboard piece. The skin trailing edge in this area is supposed to be in contact with the flap (where most folks use stainless steel tape). A protruding rivet head obviously would cause a problem. I fixed it by bonding a small piece of 0.004" thick shim stock to the underside of the skin

I first used a small diameter coarse sanding drum on the underside of the skin to prepare the surface and reduce its thickness some. The shim stock material was cleaned by using a Scotchbrite wheel on it. I then used Marine Tex to bond the shim stock material to the skin. Marine tex is an epoxy fiberglass boat repair material that adheres well to metal and is very strong. I clamped the two pieces tight and let it sit overnight. The excess epoxy filled the hole when clamped. A little sanding was necessary to remove epoxy which had oozed out from the clamping. The result was a smooth surface on both sides which will be totally undetectable when painted. Any epoxy which sticks to metal would work as well as Marine Tex. - Brian Moen-tenich

**Spare Aluminum**

One interesting thing I have found to do with the left-over aluminum from the one-piece top skins is to sell it to your local A&P or trade it for services. Two different ones in this area were glad to make a deal. - Frank Justice

[I found another use -- fabricate a new W-604 (inboard bottom wing skin) after you misdrill the first one! - Ed]

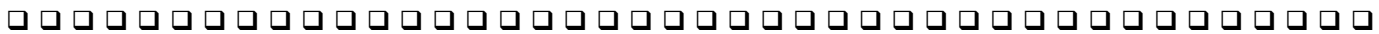

**Project Status**

**Randall Henderson:** I admit, that was me you heard whining the other day about the fact that my RV-6 project is only one of FOUR airplane projects I've managed to stick myself with in my (single car) garage right now. In addition to my wings (one of which is mostly complete, the other about half done), I'm working on stripping and painting the RV-3 prototype's engine mount, flap mechanism and stick mechanism, patching the fiberglass cowl of the Citabria that I'm a partner in, and painting "Aileron Cafe" on the RV-6 aileron that Carl Hay donated to the EAA Chapter 105 "Breakfast Club". Oh yeah, and I'm also building a "Big Ugly II" -- another temporary garage extension/eyesore. One of these days I hope to actually get some quality time on my RV again.

**Ken Scott** has been working on **Steve Harris's** RV-4 lately, which he calls a "mental health project" -- it seems that NOT working on an RV after five years building his -6 was starting to get to him. Steve has been stalled for a while, so they moved his fuselage (which is in the "canoe" stage), into Ken's garage, and they've been going after it together. **Jerry VanGrunsven** showed up one day with several "comfort tips" -- seat angle, foot wells, and other suggestions for adjustments to make the cockpit easier on the "back side". Ken says that working on an RV-4 has the added benefit of giving him experience he can apply to his RV-4 tech support calls at Van's.



**New Members & Guests**

New Member **Ralph Schildknecht**, who many of us already know from the EAA Ch105, should be started on his RV-6A by now, according to his plans at the time of the December meeting.

**Gary Whitcher** bought a set of RV-6 plans recently and signed up at the EAA Ch105 meeting. He told me he flies both ultralights and production planes, and figures there's no sense NOT getting an RV when an ultralight can run in the neighborhood of \$15,000 these days. Makes sense to me!

**Richard Kelly** showed up as a guest, left as a new member.

Guests at the meeting included **Dan Harris, Don Eisele, Ernie** (didn't catch his last name), and **Cheryl Kaluza** (not really a guest --after all it was her husband's shop we were in).



**New Section: The Tool Exchange**

*One of the great things about being involved with this group is not only exchanging tips and tricks, but with sharing specialized TOOLS and JIGS. I personally have benefited quite a bit from the fact that some builders have specialized tools that they are willing to loan out, or jigs that they don't need any more and are willing to pass on. Brent Olghren originally came up with the idea, and was the official "keeper of the tools" for a while, but it turned out to be difficult to keep track of what items are available and who has them. Accordingly, this column will be devoted to listing available items on a recurring basis, as well as requests for specific tools or jigs. Any items you want to rent (for shame!) or sell will still go in the "Don't want ads".*

Surveyor's transit level -- makes fast, accurate work of leveling your wing spars in the jigs. Bill Kenny, 590-8011.

Wing Skin Back Riveting Contraption -- large, counterweighted bucking bar and suspension system, and offset back rivet sets. (See "Back Riveting Wing Skins, December 1994 issue). Bob Neuner 771-6361.

4x4 posts for 2 wing/tail jigs. Frank Justice 590-3991.

Brent Olghren has a loose-leaf binder full of info-packs on various optional items, particularly electronics and avionics. His number is 288-8197.



**Don't Want Ads**

*Let us know what you got but don't want, or vice-versa. Ads are FREE.*

NEW Com 810 720 channel w/tray, \$935. Van's Aircraft 647-5117

Heated Pitot-tube (Piper blade style), missing heater element, \$35. Brent Anderson 646-6380

Std RV-6 elevator trim control knob/cable. Slightly used, sell for \$\$ less than new, Evart Eyres, 648-3564.

Standard Gascolator and mount for RV, slightly used. Sell for 60% of new cost. Need, good quality (RC Allen?) Horizontal Gyro, 3000fpm VSI (too much aerobatics). Don Wentz 543-2298

Skip Dennis wants to "buy-in" to an RV project. He has 'some' time to help, but has more \$\$ that he is willing to pay into a project to help finish it. If you are to the point you may need a partner to help buy that engine and panel, maybe this could work out. Give him a call at 655-7226.

3-month old Ilmorrow 920, GPS-North American Continent database. Wally Anderson 623-2328 work, 342-5240 home

Duckworks Landing Lights. Retro-fittable, light, easy installation. Kits start at \$69 (discount for Ptl'd RVators). Don Wentz, 503-696-7185 for info.

Wacky Willy's still has lots of those cool sets for rivet guns, for \$5 each. Also jewelers file sets (handy for deburring tight corners, etc.) for \$5.

