

HOME WING



Newsletter of the Home Wing of Van's Air Force

Builders and Fliers of Van's RV Series Aircraft



Scott McDaniels gives the group a primer in the fine art of dimpling at the August Home Wing meeting.

Editor's Hangar

This year I made my first ever trek to AirVenture. Wow, the entire world of experimental aviation right at your fingertips! Talk about who's who... I was wandering around the museum and noticed a group of people congregating. I asked one of the volunteers (there are LOTS of them, and they're all helpful and friendly) what was going on. She said that Dick Rutan

was going to give a presentation on the voyager flight at 1:30 pm right there in front of the Voyager display. I looked at my watch, it was 1:25 pm. Great! I sat down on the floor in the front row as someone made their way up through the crowd beside me and asked what time it was... it was Dick Rutan. He then proceeded to give a riveting (no pun intended) presentation on the voyager mission. What a treat!

Then I wandered over to one of the vendor display

(Continued on page 2)

(Continued from page 1)

buildings for a close perusal. Oh, did I mention that it was over 100 degrees in there? As I'm wandering slowly down one of the aisles, making sure I miss nothing, someone bumps into me. I turn to my left to see who it was and instantly recognize Chuck Yeager. Just then two teenage girls ask him for his autograph. Gee, I wonder if any *right stuff* rubbed off on me? So you see it can be fairly said that I rubbed elbows with famous aviators at OSH.

If you haven't been to OSH I highly encourage you to go. If you're building an airplane perhaps the best part is seeing every vendor you could want right up close and personal. Getting to actually see the products and talk with their designers was hugely beneficial. Some of the high points for me; I spoke with the Navaid folks, asked a bunch of questions that had been lingering in my mind, and then ordered a unit (November delivery). By stopping by both the Icom and David Clarke booths I was able to resolve a problem getting my ANR headsets to work with my handheld by speaking directly with the DC Product Manager. I met Bill Bainbridge of B&C fame and asked a bunch of questions thus making the decision to order his alternator and alternator control unit. I spoke with D.J. Lauritsen of Cleaveland Tool and ordered my seats (December delivery) after discussing all the options with her. BTW, she's really a nice lady, I see why so many people have her make their seats. Then I happened to wander by the Andair booth, stopped in to say hi since I had bought both their fuel selector valve and their gascolator, and was shown their new tail-wheel! Wow, had to have it, see the picture and review elsewhere in this issue. Oh, and did I mention the gorgeous new Garmin 295 color moving map GPS? Lastly, did I mention that it was HOT? I really felt sorry for the Van's crew, their spot seemed especially hot for some reasons so I didn't hang out there too much.

You OSH veterans are probably thinking "rookie, easily impressed". Well, we've all got to be a rookie once, and it sure was fun for this rookie.

Regarding this issue, I've included what is supposed to be an annual feature, the member directory. As with last year I've included enough information to allow us to contact each other but no addresses to provide at least a bit of privacy.

Remember that the Van's Homecoming is this coming weekend (Labor Day weekend, September 4th, 5th, and 6th). Those of you with e-mail have already received Bill Benedict's request for volunteers to park arriving aircraft, call him if you can spare an hour to help out.

Lastly, an electronic publishing update. I'd like to remind those that haven't tried it yet that this really is a

great way to receive your newsletter; it's faster, is in color, looks great on the screen, and can be printed on your own printer in either b/w or color if you have it. Just send me an e-mail for a trial sample.

...Randy



Events Calendar

Meeting coordinator:
Randall Henderson
503-297-5045
randall@edt.com

MONTHLY MEETING:

2nd Thursday of every month at various locations, 7:00 pm.

This month: 9/9/99

The September meeting will be at Randall (RV-6) and Rob's (RV-4) hangar at Hillsboro Airport (NE Tees, #A2). Will they be flying yet? You'll have to come out to find out! As this is being written, they are both wrapping up the final details on their planes.

Directions:

From Portland: take Sunset Highway (US 26) west to the Helvetia Road exit. Turn left (south) off the exit, turn right where it Ts onto Cornell Road. Turn right into the airport, and right again to go to the NE T-hangars. Someone



should be at the gate to let people in between about 6:45 and 7:30. If there is no one there, call 503-539-1295 (be sure to write this number down or bring the NL with you in case you are late and get stuck outside the gate.)

From Hillsboro: take Cornell road North, turn left into the Hillsboro Airport, turn right to go to the NE T-hangars. The hangar is A-2, it's in the last row on the right as you're driving in (first row on the left if you fly in), facing runway 02/20.

Tentative future meeting schedule:

October: Robin Wessel's RV-6A (fuselage in jig)
November: t.b.d.
December: t.b.d.

EAA CHAPTER 105 Pancake Breakfast:

First Saturday of every month at Twin Oaks Airpark, 8:00 am, \$4.00 (always lot's of RVs to look at too!)

This month: 9/4/99

EAA CHAPTER 105 Monthly Meeting:

Third Thursday of every month at the EAA 105 hangar/clubhouse, Twin Oaks Airpark, 7:00 pm

This month: 9/16/99

Subscriptions Due

Mail subscribers: Your renewal date is in the upper right corner of your mailing label. Use the form at the back of this newsletter if there are any changes, otherwise just mail a check to the editor, or pay at a meeting.

E-mail subscribers: Look for your name and renewal date in the e-mail that the newsletter is attached to.

All subscription data is tracked in an Access database. Data entry errors can happen - if you find an error in your renewal date please contact the editor.

August Meeting Recap

The August meeting was held at the home/garage of yours truly. Thanks to all the intrepid souls who ventured all the way over to Camas through the nasty traffic that evening to join us for BBQ chicken dinner.

Since Randall wasn't able to attend, I called the meeting to order, introduced guests and new members, and reviewed milestones. Norm Rainey made his first flight in July, and Randall has moved his fuselage to the hangar. Congrats to you both!

We then continued a discussion begun at the July meeting on which tools we should buy. The leading candidate remained a set of scales for accurately weighing our craft. Don Wentz and Gary Dunfee had both done some research and Don found the best deal in an auto racing supply catalog. The group voted unanimously to make the purchase which Don has subsequently done. The purchase totaled \$1,033 which was covered from our checking account.

Management of the group's tools was also discussed. It was decided that none of the more extreme management measures that had been discussed will be used. See the separate notice on this issue elsewhere in this issue.

Next up, I assembled a few things for show 'n tell. The first item was the model 38308 HVLP conversion gun from Harbor Freight Tools that is gaining much popularity among the folks on the RV List. The second was the neat new lightweight pneumatic tailwheel from the folks at Andair over in England. See the articles elsewhere in this issue for more information on both of these items.

Lastly, based on conversations going on around the meeting on the subject of the correct way to dimple, Scott McDaniels agreed to do an impromptu presentation on dimpling. He took us through the proper tools and techniques and did some dimpling on a spare skin to demonstrate both the right and wrong way to dimple. Oversimplified version; make sure you are dimpling hard enough to see a halo from the dimple dies around your dimple. Thanks Scott!

...Randy

Pretty Panels

By Randall Henderson

When it came time to do the lettering on my panel, I decided to get fancy and have it silk-screened. This would probably be considered a relatively "high-end" panel treatment, and you can obviously get by with less money and effort. My main purpose in writing this article is to share information about the choices and comparisons I made in this phase of the project, not to necessarily promote any one method over another.

I used a CAD program to make up the lettering, and instead of trying to make a full sized drawing, I split it up into several different areas, each area indexed off of centering crosshatches in a hole or set of holes. This involved a lot of printouts from the laser printer and holding them up to the panel to make sure they were right. When I was satisfied, I output the results to EPS (Encapsulated PostScript) format files and took them to LazerQuick, where they output film positives for about \$10/sheet (3 sheets). I then took the films to a screener (Joel Slenning, Zag's screen printing 503-516-5250 jslen87012@aol.com) who cut them up into the individual areas, made screens from those and went from there. Cost for the screen work was \$100.

Things got a bit messy at this point — the screener made a boo-boo on the first try, and although he was very responsive and paid the cost to have the panel re-

(Continued on page 4)

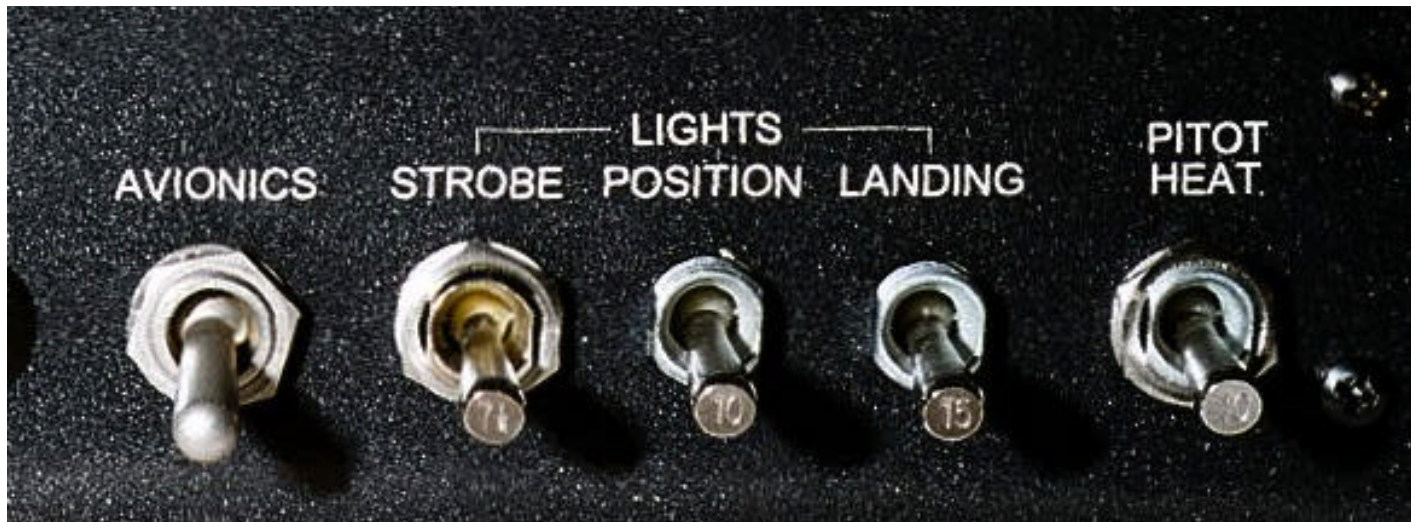

(Continued from page 3)

painted by a professional shop, and re-screened it at no extra charge, the paint shop screwed up too, completely ignored my detailed written instructions, wouldn't admit fault, made me buy the paint to re-paint it again, and held my panel hostage for "COD" payment, which was not the original agreement. Quite a frustrating fiasco, but in the end I did at least wind up with a much better paint job than I had originally done myself. Evidently other people have had good experiences with this paint shop (Lotus Precision Coatings) but based on my experience I sure can't recommend them.

One problem with going the silkscreen route instead of using engraved placards or stick-ons, is that once it's done, it's DONE — if you want to change or add something later on, it's difficult if not impossible to update the lettering and make it look the same without redoing the whole thing. Of course I did run into this — found a couple of small things that I needed to add. Fortunately they were relatively unobtrusive items, so I decided to try just getting the text printed on vinyl at a sign shop. (Printing onto clear plastic with a laser printer is also an option, but only if you have a light colored panel and black lettering.

Which of course is the opposite of what I have.)

I originally thought a basic sign shop like Signs Now, Fast Signs, etc. would be able to do this. But they wanted way too much money for it (\$48-60!) and they couldn't read the EPS files anyway. After much running around I discovered that the people at Oregon Blueprint are the real pros. Not only can they handle the EPS files, but they will do an 8.5 x 11 sheet on sticky-back vinyl, with plastic laminate overlay, for a whopping \$12.50. The result came out looking pretty good. For someone who wants to go a simpler route than I did, I would recommend looking at using this method for all your lettering.

Since I only really needed just a few small bits of additional lettering, it occupied just a fraction of the standard minimum 8 x 11 sheet. So I made duplicates of some of the lettering to fill in the extra, including about 12 copies of an "UP - PITCH TRIM - DOWN" RV-6/6A manual trim circle. This is similar to the plastic trim ring that Cleaveland sells in their catalog. I will bring my extras to the next meeting and make them available to anyone who thinks they could use one for trim knob.

(Continued on page 5)

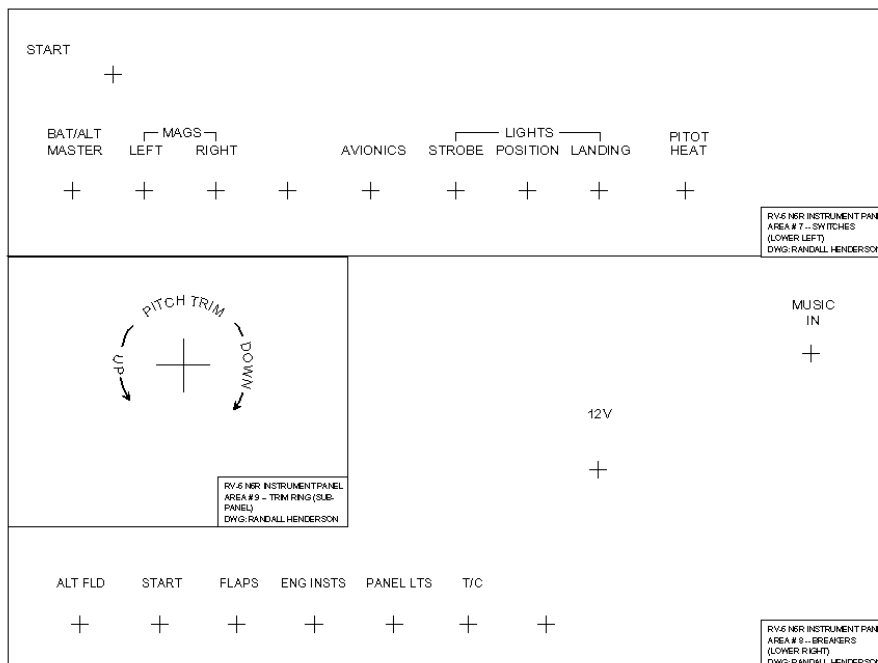

(Continued from page 4)

Note: Just before I submitted this article for publication, the May issue of the Chapter 105 newsletter came out, with a reprint of an article on how to do panel lettering using custom-made rub-on transfer lettering. Frankly that method looks like it could have some definite advantages over the route I took, not the least of which being cost. However, Dan Benua, who is about at that stage, looked into it, and found that custom transfer lettering seems to be something of a lost art, as he wasn't able to find anyone who could do it. He also called the screener who did my panel, and found that he has gotten some more experience with screening aircraft panels, having done some panels for Evergreen Helicopters, and has modified his technique somewhat to use a full size film. So if you go the silkscreen route, be sure to check with the screener first to find out what format they'll want the lettering in.

Next Month: Complete instrument lighting system for \$8.94. Total.

...Randall

Goodness Gracious

By Kevin Lane

I admit, it was my idea, everyone gets a ride before the monthly meeting. I didn't really think too hard about the logistics. You know, all the flying RV's show up, give a few rides, everyone has "the grin" and goes home to work on the plane even though it's 10 pm. Tuesday I was at Troutdale shooting some touch and goes and checking out my new mag timing. Two total strangers came up and informed me that they were giving free RV rides Thursday night. I called Bill that night to find out if I could expect any company support.

It was only 5:30 on Thursday and already there were several dozen people milling around. My plane started very hard. It had been running fine on Tuesday. It had flown 50 hours to the Bahamas and back via North Dakota and run strong. My engine has no primer system on it. I was told that O-320's don't really need one, and I had admittedly reached the point of wanting to stop building and fly.

During the winter months I had gotten use to pumping the throttle quite vigorously to get things started, nothing else seemed to work. My engine never started the way I was taught where you simply give it 1/4" of throttle and crank it. It always seem to require full fire-wall setting. I thought with all the people around it would be foolish not to shut off the engine when chang-

ing passengers. When my third passenger climbed in I cranked and nothing. I instinctively pumped the heck out of it and cranked again. Nothing, it would start to catch but never jump to life. More pumps and some funny sounds, but no start. Then lots of arm waving from the crowd. What do people do when a plane catches fire? They run over of course. Maybe the whole thing will blow up. Wouldn't want to miss that! I quickly realized what had happened and had enough battery power left to crank and blow it out. I probably could have gotten it started but it felt like time to call it a day. How embarrassing in front of the crowd. The idea though of burning up in front of the group ranked right up there with the day when I landed at Sunset and after setting down past the little mound mid-field realized that the very wet grass was as slippery as snow and the factory hangar was getting bigger awfully fast. It would be bad enough to wreck your plane but to take out the entire factory fleet too!

I know, this story is going on and on, but Randy likes them that way. So Friday I installed a new air filter since mine was burned through in places. I pulled the left mag. Despite having symptoms of a broken impulse coupler spring it was OK. In rotating the mag by hand everything seemed to work fine and all looked brand new, being only 450 hrs old. I did get the impulse to not fire a few times, though I don't know if hand cranking speed is valid. I cleaned it up, reinstalled it, and have had no further problems this weekend after three hours of flying. I have had the engine start by giving it a 1/4" of throttle and not pumping it, just like it should. My starter is old and doesn't crank real fast, which may be a factor. Sunday I gave an RV builder in Kelso a ride. He said he hadn't had one in 4 years. He responded with a hearty "hell, yes" when asked. He owes me a ride in his some day.

Life is good again.

...Kevin

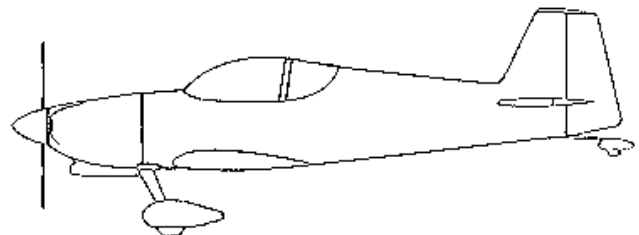

Andair Introduces Lightweight Tailwheel

By Randy Lervold

While walking the rows of vendor displays at AirVenture I spied the booth of our English friends at Andair who make those great fuel selector valves and gascolators. Upon wandering in and introducing myself as the owner of both products I was thanked for my support and show their latest baby... their new lightweight tailwheel. Folks, this thing is a work of art! The machining is gorgeous just like the rest of their product line (or "range" as they like to say across the pond).

Of course my RV-8 is a long ways from flying so I can't comment on its performance, but someone else who was at OSH who has a flying RV-4 also bought one and immediately put in on. I've snipped his review which was posted to the RV List. Oh, by the way, they were selling them for \$65 at OSH, and Bill Benedict tells me that Van's intends to carry them although I don't know at what price (\$65 may have been an AirVenture special).

RV-List message posted by: RotaVR@aol.com
All;
I purchased one of Owen Phillips 6" Andair pneumatic tail wheels at Oshkosh to replace my

original Vans' hard rubber installation. \$68 with tax. Installed same this morning, and offer following observations: Pro: The pneumatic unit is noticeably lighter than the hard rubber tire and wheel, although I did not weigh them, simply hefted one in each hand. Straight forward swap from one to the other, using existing hardware. The pneumatic tire provides the tail and aft portion of airplane a much softer, more quiet ride over taxiway / runway cracks. This was readily apparent even when pulling the airplane out of my hanger. My hanger center section floor sits approx 3/4" higher than ramp and pneumatic does not 'bounce' the tail spring as the hard rubber tire does. The tire seems to roll more easily in grass than the hard rubber. I have almost 700 hrs with the hard rubber tire /RV-4 combo and the pneumatic seems to take slightly less force on the pedals to make a turn while taxing. I assume the pneumatic will absorb some of the shock load that is currently transferred via hard rubber tire-to tail-spring-to tail cone area. Making life a little easier for the aft fuselage section. Cons: replacement hard rubber is \$16, pneumatic tire is \$20 and tube is also \$20. The rubber composition of pneumatic "feels" quite soft. May not wear very well. The pneumatic is probably more susceptible to shimmy. The pneumatic will require more maintenance. (proper air pressure)
For what it's worth.
Steve Schmitz



New Andair lightweight pneumatic tailwheel next to Van's hard rubber unit.

Toolaholic

By Randy Lervold

At the August meeting I showed a new HVLP conversion gun I recently bought at Harbor Freight Tools in Portland. This gun has been getting rave reviews on the RV List. Specifically it is the model 38308. It has a normal retail of \$59 and was on sale in the store for \$49 (still on sale as of this writing). If you just happen to stumble on their web site, as I did AFTER I bought the gun, you can get it for \$39. Someone at the meeting mentioned that if you print the web price and take it in they will honor it in the store.

Even though I am not close to painting my airplane, which I intend to do myself, I have been doing all the research I can so that I have some idea what to do once I get there. That's why I bought this gun — to try it out and see if its good enough to paint my whole plane with.

Coincidentally I was in researching paint at the auto body supply place where I intend to buy all my supplies (Northwest Auto Body in Orchards, WA) and saw the EXACT SAME gun only in red and with a fancy retail box around it on display at the store for \$129. I looked closely, it is the same gun. I probed at length with the folks there about the other higher-end guns they have there from Devilbiss. In particular there is one they recommend that they sell for \$359. I asked several questions to ascertain the difference. The most important points I got back was that for a professional the Devilbiss would last longer in daily service. But when I asked if there was any differ-



Model 38308 HVLP gun from Harbor Freight Tools. A screamin deal at

ence at all in the quality of the spray pattern the two guns put out he said "nope, you won't notice any difference there at all".

My plan now is to use this gun for priming (where I have been using one of those crummy little detail guns with the 8 oz. Cup) and to paint my interior. If it works well then what the heck, I'll paint the whole plane with it. At this price one could easily buy another one for the actual paint and use the first one for priming only.

...Randy

Ps. Hey Kevin, get one of these and paint your own plane!

Harbor Freight Tools
Page 1 of 2

Painting Supplies

Paint sprayers, tarps, brushes: just about everything you need to start painting but the paint. Are you a contractor? Are you an auto detailer? Do you just want to paint your house? It doesn't matter who you are. We have your equipment and more right here!

HVLP GRAVITY FEED SPRAY GUN

Get a superior finish and save paint at the same time! High volume low pressure technology applies paint with less force, meaning less paint "bounces" off the surface into the air. Stainless steel needle and tip allow use with water-based material. Includes air regulator.

Item No. 38308-2VGA

~~549.99~~

\$39.99

Check Out These Featured Items!

34775 GRAVITY FEED HIGH VOLUME, LOW PRESSURE SPRAY GUN

\$169.99

37515 2-1/2 GALLON PRESSURE PAINT TANK

<http://www.harborfreight.com/cpi/html/paintsupp/>
8/20/99

Special Offer!

28 PC. HIGH SPEED STEEL DRILL BIT SET

ITEM 00866-SVGA

\$7.99

HARBOR FREIGHT TOOLS AUCTION

For special sales information, new products and more, enter your email address here:

-
- Home
- Search
- Clearance Items
- Free Catalog
- About Us
- Order From Printed Catalog
- Retail Stores
- Customer Service
- Inside Track Club Members
- Hot Links
- Review Shopping Cart
- Employment Opportunities

Name	City	State	HomePhone	WorkPhone	E-mail	Type
Anderson, Alan	Vancouver	WA	360-687-3092	360-696-0471	dental-smiles@juno.com	RV-4
Anderson, Brent	Portland	OR	503-646-6380	503-598-6132	brenta@mfg.com	RV-4
Asher, M.E. (Mac)	Alpine	WY	654-7717		mcash@silverstar.com	RV-6
Baker, Gary	Medina	OH	330-725-3569		gtbaker@bright.net	RV-6
Barringar, Al	Goldendale	WA	509-773-3150	541-298-0884		RV-6
Battjes, Carl	Portland	OR	503-293-4353			RV-6
Beauchamp, Bruce	Camas	WA	834-4706		blb@easystreet.com	RV-6A
Benedict, Bill	Aloha	OR	503-649-8707	503-647-5117	billb@europa.com	RV-4
Benua, Dan	Portland	OR	503-621-3323	503-531-2263	danb@synopsys.com	RV-6A
Best, Michael	Sioux Falls	SD			michaelgb@uswest.net	RV-9
Billiar, Mike	Beaverton	OR	503-645-1946		your6a@aol.com	RV-6A
Bilodeau, Paul	Parlin	NJ	908-840-4422	908-957-6611		RV-6A
Bonesteel, Wayne	S Lake Tahoe	CA	530-542-3945	530-542-0871	wayneb@oakweb.com	RV-4
Bonneville, Stephen	Aloha	OR	503-649-9207	503-230-3804	sbonneville@bpa.gov	RV-8
Boring, Robert	Gresham	OR	503-661-7627		carbobbor@aol.com	RV-6A
Bourgeois, J. Rion	Beaverton	OR	503-646-8763	503-670-1144	rion@att.net	RV-4
Bowers, Jeffrey	Portland	OR	503-246-2631	503-299-5662	friebow@juno.com	RV-6A
Bowhay, Eustace	Blind Bay	BC	250-675-4428			RV-6
Braun, Robert	Hillsboro	OR	503-681-8144		bobs78@prodigy.net	RV-8
Bright, John	Newport News	VA			john.bright@bigfoot.com	RV-6
Bronson, Tim	Pittsburgh	PA			70773.2700@compuserve.com	RV-8
Buchanan, Sam	Athens	AL			sbuc@traveller.com	RV-6
Butt, Rob	Mulino	OR	503-632-7990	503-335-2517	N7MZR@aol.com	RV-6A
Cannon, Walt	Seattle	WA	206-524-7221			RV-6
Carlson, David	Portland	OR	503-			RV-6A
Chambers, Scott	West Linn	OR	503-656-7019			
Christner, William	Molalla	OR	503-829-2856			RV-4
Cone, Jim - VAF - Tri-State WIng	St Charles	MO	314-928-8703		jamescone@aol.com	
Conley, John	Independence	OR	503-606-0775	503-784-3134	john.conley@att.net	RV-6A
DeLano, Dan	Independence	OR	503-838-4412			RV-6
DePute, Larry	Juneau	AK			ldepute@gci.net	RV-4
Drake, William	Battleground	WA	360-687-1698	360-687-1698		RV-6
Dralle, Matt G. - RV List Administrator	Livermore	CA	510-447-9886	510-606-1001	dralle@matronics.com	RV-4
Dunfee, Gary	Beavercreek	OR	503-631-7262	503-631-4757	gary.dunfee@med.ge.com	RV-6A
Dyess, J.D.	Pflugerville	TX	512-255-4237			RV-8
Elford, Jon	Banks	OR	503-324-0209	503-648-6554	jelford@transport.com	RV-6
Elsner, Bernie	White Salmon	WA	509-493-2161			RV-4
Faatz, Mitch - Bay Area RVators	San Jose	CA			mfaat@agenttech.com	RV-6A
Fogg, Ray	Hillsboro	OR	503-538-1661	503-350-7393	ray_fogg@credence.com	RV-8
Franich, Jim	Canby	OR	503-651-3483			RV-6A
Fritz, Bob	San Mateo	CA	415-573-5258	408-235-6475	qmaxllc@aol.com	RV-6
Funk, David	Hughson	CA	209-883-1812			RV-6
Godsil, Galen	West Linn	OR	503-635-6497		ggodsil@teleport.com	RV-8
Gold, Andy - RV-ation Bookstore	Tabernash	CO		970-887-2207	winterland@rkytmtnhi.com	RV-6A
Graham, Gary	Hillsboro	OR	503-648-6123		beeb@teleport.com	RV-4
Graves, Mike	Hillsboro	OR	503-356-1923		mgraves@dalsemi.com	RV-6A
Gray, Bruce	Gardnerville	NV	775-265-5790	775-687-8833		RV-4
Griffin, Randy	Vancouver	WA	360-944-7400	360-212-2959	randy_griffin@hp.com	RV-8
Haan, Bob	Scappoose	OR	503-579-2729	503-579-3675	shaan@easystreet.com	RV-6A
Hall, Jerald	Scappoose	OR	503-543-5902	503-696-2013	khall@columbia-center.org	RV-6A
Halverson, Greg	Aloha	OR	503-591-0105		cando16@aol.com	RV-6

Hamilton, Keith	Longview	WA	360-636-2369		greatteeth@solidnet.com	RV-6A
Hammell, Pat	Cornelius	OR	503-640-9414	503-532-0962	phammell@teleport.com	RV-6A
Hanson, Gary	Hillsboro	OR	503-628-2405	503-628-0312	slhanson@teleport.com	
Harris, Steve	North Plains	OR	503-647-1989	503-671-5437	steven.l.harris@juno.com	RV-4
Hay, Carl	Portland	OR	503-297-3091		heyheyhay@aol.com	RV-6
Henderson, George	Portland	OR	503-649-0741		gmhski@teleport.com	
Henderson, Randall	Portland	OR	503-297-5045	503-690-1234	randallh@home.com	RV-6
Hevern, Gerald	Camas	WA	360-834-4619			RV-6
Hickman, Rob	Beaverton	OR	503-524-3190	503-598-7727	robhickman@aol.com	RV-4
Hoffman, A. J.	Gresham	OR	503-661-7712			RV-4
Hopple, Jon	Aloha	OR	503-642-7928		hopplejs@tvfr.com	RV-6A
Hormann, Doug	Hillsboro	OR				RV-6
Hosler, Greg	Portland	OR	503-515-4990			
Householder, Steve	Yamhill	OR	503-662-3697	503-297-8760	staghollow@aol.com	RV-6A
Jackson, Dennis	Independence	OR	503-838-4746	503-838-2579	denny@tms-usa.com	RV-4
Jasinsky, Jeff	Camas	WA	360-834-6315	360-212-8565	Jeff_Jasinsky@hp.com	RV-8
Johansen, Steve	Salem	OR	503-363-5695	503-378-4168 x250		RV-8A
Jordan, Terry	Cornelius	OR	503-693-0459		ace@pacifier.com	RV-6A
Justice, Frank	Beaverton	OR	503-590-3991	503-264-1483	Frank.k.Justice@intel.com	RV-6A
Kenny, Bill	Sherwood	OR	503-590-8011	503-590-3342	orazinc@ix.netcom.com	RV-6A
Ketter, Ralph	Chandler	AZ	602-831-7460		Ralph.Ketter@AlliedSignal.com	RV-6
Key, Max	Carrollton	GA	770-830-6422			
Kimmell, Rodney	Gaston	OR	503-985-7808	503-985-0606	rkimmell@protean-tech.com	RV-6
Kimura, Steve	Corvallis	OR	541-753-9749	541-715-8287	skimura@dnc.net	RV-6A
Koch, Frank	Independence	OR	503-838-0572	503-691-2601 x329	bkoch@schn.com	RV-6
Lane, Kevin	Portland	OR		503-233-1818	n3773@mciworld.com	RV-6A
Lang, Peter	West Linn	OR	503-636-4006	503-571-5726	langp@teleport.com	RV-6
Lange, Harmon	Warren	OR	503-397-6916	503-397-1478	marcy@langair.com	RV-6A
Lattner, Ron	Banks	OR	503-324-8703		rattner@magic.hurrah.com	RV-6
Leacock, Art	Ridgefield	WA	360-687-6821			RV-4
Leeman, Larry	Portland	OR	503-274-4197	503-618-2848		RV-6A
Lervold, Randy	Camas	WA	360-817-9091	360-944-3702	randyl@firstaidonly.com	RV-8
London, Don - Aviacomp	Scappoose	OR	(503) 543-3986		aviacomp@teleport.com	RV-6A
Long, Scott	Portland	OR				RV-6A
Lorz, Terry	Portland	OR	503-244-7041		tlorz@netcom.com	RV-6
Louris, Tom	Lake Oswego	OR	503-598-4676		twlflying@aol.com	RV-6A
Lyshaug, Pete	Portland	OR	503-246-0452			
Mack, Don & Chuck	New Lenox	IL			dmack@tuthill.com	RV-6A
Madonna, Michael	Woodland Park	CO	719-227-9745			RV-6
Matlack, Dean	FPO	AP			dmatlack@cwnetdg.io	
McDaniels, Scott	North Plains	OR	503-647-2764	503-647-5117	smcdaniels@juno.com	RV-6A
McGee, Mike	Vancouver	WA	360-944-5473	503-227-5581 x 5403	jmpcrftr@teleport.com	RV-6
McHenry, Ted - Western Canada RVators	Surrey	BC			tedd_mchenry@hp.com	
Melvin, Ken	Hillsboro	OR	503-693-3645		kmelvin@teleport.com	RV-4
Miller, Joe	Hillsboro	OR	503-647-2059		jwcmcm@aol.com	RV-6A
Miller, Gary	Beaverton	OR	503-524-8269	503-350-5848	gary.miller@poorman-douglas.com	RV-6A
Mitchell, Jim	Portland	OR	503-644-5228			RV-8
Moentenich, Brian	Portland	OR	503-666-7518	503-326-3840	brian.l.moentenich@usace.army.mil	RV-6
Moran, Patrick	Portland	OR	503-257-7536			
Moscarelli, Andy	Mooreville	NC	704-664-3842			RV-6A
Mulherin, Harold	Vancouver	WA	360-573-6362		mulherins@wa-net.com	RV-6A
Ohlgren, Brent	Portland	OR	503-288-8197	503-228-7307	obrento@mail.aracnet.com	RV-6A
Olender, Henry	Palo Alto	CA	650-325-0591			RV-4
Palinkas, Gary	Parma	OH	440-845-1330	440-885-8850	GLPalinkas@aol.com	RV-6

Park, Gene	Newberg	OR			gpark@teleport.com	RV-8
Patchett, David	Vale	OR	541-473-2785		mpatch@micron.net	RV-6
Phy, Thomas	Portland	OR	503-452-3743	503-452-3743	green26@juno.com	RV-6
Pierson, Jack	Newberg	OR	503-628-0215			RV-3
Porter, John	Newberg	OR	770-924-3354		71714.2624@compuserve.com	RV-8
Potter, Mark	Portland	OR	503-872-7090		potterlaw@aol.com	RV-8
Psiropoulos, Michael	Hillsboro	OR	503-681-3088	503-684-5384	psirops@easystreet.com	RV-6A
Psiropoulos, Dean	Hillsboro	OR	503-681-0183	503-684-5384	104222.2455@compuserve.com	RV-6A
Purinton, Nelson	Bristol	VT				RV-8A
Rainey, Norm	Vancouver	WA	360-256-6192	360-696-0088	NormRainey@aol.com	RV-6A
Reisdorfer, Mark	Floyds Knobs	IN	812-923-5059	800-228-2739	mreisdorfer@ipapilot.org	RV-8
Robles, Leejay	Portland	OR	503-257-9832	503-618-6700 x 301	flywizard@coho.net	RV-6
Rosenzweig, Charles	Longview	WA	360-577-6407		searose@kalama.com	RV-6A
Scott, Ken	Aloha	OR	503-649-3252	503-647-5117	kenrv6@yahoo.com	RV-6
Simpkins, Dave	Zig Zag	OR	503-622-3854		DSIMP6125@aol.com	RV-6A
Smith, Dick	Austin	TX				RV-6
Story, Ron	Lake Oswego	OR	503-699-6402		rstory@pacifier.com	
Strickfaden, Al	Battle Ground	WA	360-687-3119	360-687-0875	joanstrick@juno.com	RV-6
Strong, Colin	Portland	OR			colin_strong@ccm.hf.intel.com	RV-6
Stugart, Jim - EAA Chapter 187	Round Rock	TX			DerFlieger@aol.com	
Stuhr, Glenn	Astoria	OR	503-458-6911			RV-6
Truax, Bill	Big Fork	MT	406-837-2377			RV-6
Valaer, David	Camas	WA	360-834-9552		valaer@juno.com	RV-6
VanGrunsven, Jerry	Hillsboro	OR	503-648-3464		rvforpla@pacifier.com	RV-6A
VanGrunsven, Stan	Vancouver	WA	360-254-3492	360-690-0136	weflyat55@compuserve.com	RV-6A
Van's Aircraft,	North Plains	OR				
Vap, Kevin - Kansas City RVators	Overland Park	KS	913-851-2289	913-397-8448 x1380	kevin@vap.org	
Warren, John	La Center	WA	360-263-7848		jwarren@ethergate.com	RV-6A
Wawrin, Barry	Aurora	OH				RV-6A
Weiler, Doug C. - VAF - MN Wing	Hudson	WI	715-386-1239		dougweil@mail.pressenter.com	RV-4
Wentz, Don	Scappoose	OR	503-543-2298	503-696-7185	don.wentz@intel.com	RV-6
Wert, Don	Portland	OR	503-464-0378	503-464-0378	rvflyboy@juno.com	RV-6A
Wessel, Robin	Tigard	OR			rywessel@aol.com	RV-6A
Weston, Carl	Aloha	OR	503-649-8830	503-690-1570x6107	carl@stt3.com	RV-6
White, Steve	Oregon City	OR	503-698-7363	503-652-4639		RV-6A
Wilson, Mike (James)	St. Helens	OR	503-397-6207		james.mike.wilson@intel.com	RV-4
Wotring, Dale	Ridgefield	WA	360-887-3196	360-694-3040	gusndale@aol.com	RV-6A
Wylychenko, Michael	Independence	OR	503-838-4987		wylychmb@aol.com	RV-4
Yablon, Brian	Portland	OR	503-293-1073	503-264-5882	brian.m.yablon@intel.com	RV-6A
Zander, Dick	Vancouver	WA	360-896-0132		dzan@pacifier.com	RV-6A

NOTES:

- Many of you change e-mail addresses and don't tell me. Please check your e-mail address here and send me an update if it is missing or incorrect... randylervold@csi.com
- Please check all other data for accuracy and notify me if anything has changed or is incorrect.
- Bill Truax; sorry, I lost your address update, please re-send it.
- Please note that I can easily send this directory as an Excel file which you can then sort on anything you'd like (such as by city, or type of project, etc.)

Home Wing Tool Policy

At the last two meetings various methods of keeping our group's tools from loss and abuse were discussed. In the end we decided that we would not initiate deposits, use fees, or personal escorts. What we decided was...

- Everything goes through Brent — do not give the tool to another member.
- Brent will keep an accurate sign-out sheet for each item so he knows where it is at all times.
- Brent will inspect all tools upon their return. If there is any damage he will ask you to pay for the repair (with the threat of public humiliation if you fail to be a grown-up).
- That we are buying new aircraft weighing scales for the group.

The ability to have occasional use of these expensive tools is a real membership benefit, let's respect the group's assets.

...Randy

Home Wing's New Scales

I can report that we took the scales out and have already weighed 3 airplanes with them — 2 RVs and a KR2. Preliminary weights only so I'm not saying what they came out at. First impression: the scales are **STONE SIMPLE** to use. I expected them to be complicated for some reason but they sure aren't, which is good news. Rob Hickman was disappointed when he first looked at the total weight on his RV-4 — that is until he heard some snickers from the back of the hangar and realized his 6 year old son was standing on the extra one.... Rob and I will be hanging on to them for the next couple of weeks, then they'll be available to pass on. Or if anyone wants to taxi/drag their airplane over to the NE T hangars at HIO, they can use them there.

...Randall

1/1/2000



Builder's Bookstore

for the builder, technician, & pilot

[HTTP://WWW.BUILDERSBOOKS.COM](http://www.buildersbooks.com)
 970 887-2207



RV-ation Bookstore is now Builder's Bookstore

Come see our new web site.
Now, fully secure and easier to use.

Builder's Bookstore: PO Box 270, Tabernash, CO 80478 Shipping is actual postage only; NEVER a handling fee.

CLASSIFIEDS...

Classifieds are free to Home Wing members. Ads will run for three months. Send to editor by e-mail or mail. Renewals ok, just let editor know. Date at end of the ad is last month ad scheduled to run.

FOR SALE

FOR SALE: 1/2 ownership in an RV-6, 160 hp O-320, 825 TTAF&PP, New top end from EC, Hartzell C/S prop., II Morrow GX-65 GPS-COM, Exlt paint-hangar baby, Electric flaps and aileron trim, \$27,500 call Larry @ (503) 655-9236 9/99

RV6/6A Empennage – Completely assembled and corrosion-proofed. Excellent workmanship. \$1,000. Mike Graves, 503-356-1923, 10/99

RV-6 wing kit for sale - No bucks and no time forces sale. Lots of work completed by award-winning builder, no work done since purchased. Spars primed and assembled, leading edges done, structure was clecoed together with ribs drilled and ready for final skin back drilling. Tanks not done, flaps/ailerons started but not closed. Kit is complete and includes fuel gauges, but no wing tips, #20476, started in 1996. Kit is in Corvallis, \$3,900. Steve, 541-753-9749, skimura@dnc.net 9/99

RV-6 kit less finishing kit - Emp complete, wings 80%, fuselage still in crate. Also have the fuselage jig. \$8,000. Must also sell RV-6 Quick build with Emp completed, dual brakes, elec tim and flaps, extra set of wing tips (the heavier ones), larger wheel pants. Kit complete less engine. \$17,900. Also have an O-320 with 1000 SMOH for \$6800. Rainpoof@aol.com, 10/99

Wing & Empennage rack — Storage rack for wing and empennage parts on casters, \$40. Contact Greg Halverson 503-591-0105 12/99

For Sale –

- O-320 brand new cylinder assembly, chrome with valves installed, wide deck. Paid \$750, sell for \$350 obo.
- RV-4 throttle quadrant with mixture & throttle cables, make offer.
- Avery 2X rivet gun with \$120 in rivet sets etc.
- Avery microstop countersink, bits other misc. tools, \$150 obo.
- Magnetos – 1 Slick 4250R, new. 1 good used Bendix S4LN-204, make offer.
- Lycoming geardrive starter, new, 144 tooth, make offer.

Contact Butch Walters, 360-636-2483 or arvnwco@kalama.com, 8/99

RV-6 Fuselage Jig – I believe mine is the fourth or fifth on this jig. I got it from Steve White and he told me that Carl Hay used it. Located in Gresham, contact Bob Borning at 503-661 7627, 10/99

Duckworks Landing Light Kit - \$55.00 Contact Brent Anderson 503 598 6132 Days 503-646-6380 Eves brenta@pcez.com, 12/99

Hangar at KSPB – Looking for a hangar on a temporary bases at a local airport? Call 503-645-1946 and asked for Mike Billiar, e-mail: your6a@aol.com, 7/99

Flightcom 40X Headsets, 2 pair – Used about 10 hrs, \$120 for both sets, includes carry case. Bill Christner, 503-829-2856, 10/99

Duckworks Landing Lights - Retro-fittable, light, easy installation. Kits start at \$69, discount for Home Wing-ers. Don Wentz, 503-696-7185

BuildersBookstore - Books and videos specifically for the RV builder and pilot. Call or write for a FREE catalog; (970) 887-2207, PO Box 270, Tabernash, CO 80478. Or see our web page at www.buildersbooks.com Featured item: 18 YEARS OF THE RV-ATOR is now available. New additions all the time!

BACK ISSUES are available at \$2.00 each including postage for hardcopy. Limited availability, contact newsletter editor. Adobe Acrobat versions free to members.

WANTED

(nobody wants anything this month)

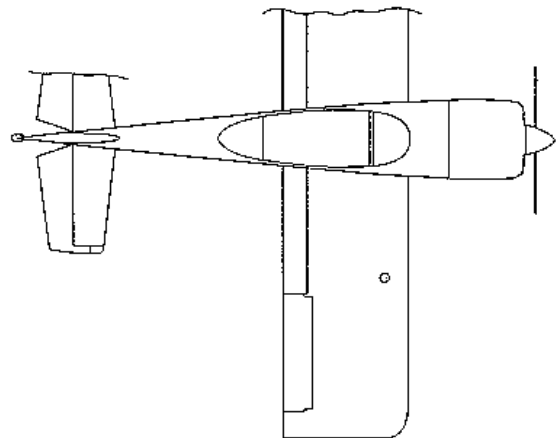

Use em!

Members are encouraged to take advantage of the classified section. Since it's free why not take a stab at unloading that unused airplane stuff. Besides, it's kind of interesting to look at all the odds 'n ends for sale.

Please note that the date at the end of each ad is the expiration date. They run for three months and then are dropped unless you want them renewed by notifying me.

...Randy

The Tool Exchange

The Home Wing owns a selection of tools for use by its members. The Toolmeister is **Brent Ohlgren, 503-288-8197**. Call either Brent to arrange use.

Remember:

- All use must go through Brent.
- You are personally (financially) responsible for any damage.

Other benevolent members also have tools they may be willing to loan. Let the editor know if you have jigs, tools, shop space, etc. to loan, exchange, or otherwise provide — at NO COST — or if you are looking for something specific to borrow. And whether your item is listed here or not, go ahead and bring it to the meeting.

Home Wing Tools
HVLP paint sprayer
Hole template for instrument panel
Wire crimping tool & die
Brake lining rivet set
Tune-up & annual kit (compression checker, mag timing light, timing dial, mag adjustment tool, plug gapper, high voltage cable tester, and plug vibrator cleaner.
Aircraft scales — allows you to accurately weigh your beast and also determine CG.

Item	Owner/lender	Phone / e-mail
Custom cutting wheel mandrel (for cutting your canopy)	Stan VanGrunsven	
Prop tach (calibrate your tach)	Butch Walters	360-636-2483
Engine stand	Don Wentz	503-696-7185
Engine hoist	Norm Rainey	360-256-6192
Surveyor's transit level (handy way to level wing and fuselage jigs)	Bill Kenny	503-590-8011
Back riveting contraption (large, counterweighted bucking bar and suspension system and offset back rivet sets)	Bob Neuner	503-771-6361
Lead crucible (for melting lead for elevator counterweights)	Doug Stenger	503-324-6993
Table saw taper jig (for tapering wing spar flange strips)	Carl Weston	503-649-8830
48" pan break located at hanger PLS D-10 at Troutdale if an RV builder needs some metal bent.	Kevin Lane	503-233-1818

Home Wing Newsletter Subscription/Renewal

Please fill out and mail to **Randy Lervold, 5228 NW 14th Circle, Camas, WA 98607**, along with \$10 for renewals or new subscriptions. *Please make checks payable to either Randy Lervold or Home Wing*. If you are renewing you only need to give your name, date, payment method, and any other information that has changed. *Use this form for address changes too!*

Name: _____ Spouse: _____
 Address: _____ Home phone: _____
 City, State, Zip: _____ Work phone: _____
 E-Mail: _____

Project: **Status:**

RV-3 Empennage

RV-4 Wings

RV-6 Fuselage

RV-6A Finish kit

RV-8 Flying

RV-8A

Payment: **Newsletter**

Check: **Distribution:**

Cash: Mail

Info change only: E-mail (pdf)

Home Wing Van's Air Force
Randy Lervold, Editor
5228 NW 14th Circle
Camas WA 98607

Disclaimer: The Van's Air Force Home Wing newsletter is in no way a publication of Van's Aircraft or any other corporation. All products reviewed or mentioned are not necessarily recommended for use by the Home Wing, but are included for informational purposes only. All builders tips represent only the means by which the builder whose name is associated with the tip chose to build his/her aircraft. Builder's tips are not meant to replace the plans and instructions from Van's Aircraft. All builder's tips are presented only as a source of information and a forum for exchange and the sharing of ideas and construction methods. NO responsibility or liability is assumed, expressed, or implied as to the suitability, accuracy, safety or approval thereof. Any party using the suggestions, ideas, or examples does so at their own risk and discretion and without recourse against anyone. The editor of the Home Wing newsletter and the builder's tips submitters are not responsible for any product or builder's tips misuse, incorrect construction, or design failure, nor any other peril. Any material printed within may be reprinted without permission, but please give credit to the original source and author. If the original source is not the Home Wing newsletter, it is not necessary to credit the Home Wing newsletter, only the original source and author. The Home Wing newsletter is published more or less monthly. Subscriptions are \$10/year. Complimentary issue for new builders upon request. Mail subscriptions, ideas, tips, tricks, and articles to the newsletter editor.

Home Wing contacts:

Newsletter Editor & membershipRandy Lervold 360-817-9091, 5228 NW 14th Circle, Camas WA 98607,
RandyLervold@csi.com
Meeting Coordinator.....Randall Henderson 503-297-5045
Fly-In Leader.....Don Wentz 503-543-2298
Official web sitewww.edt.com/homewing