

## HOW TO FLY/HOW NOT TO FLY (Part II)

### COULD YOU PASS A PRIVATE CHECK RIDE TODAY?

While it seems a silly question, the answer may not be as positive as you'd like to think. Many of us let our flying skills get rusty over the years. Maybe we develop flying habits different from those we were taught; maybe some of them are bad habits. Maybe we feel that some of what we learned in training is not relevant to the flying we now do, so there is no need to practice that stuff anymore. You may have a thousand hours in your log book, but does that automatically make you a better pilot than someone else with only 100 hours? Maybe you have only 100 hours experience, repeated ten times. Or, you may have slipped into bad habits and regularly demonstrate less skill than a much lower time pilot.

OK, assuming that you could pass the private exam today. That's fine. But you have amassed over 500 hours (or whatever) in your logbook. Could you satisfactorily perform the maneuvers and standards of the Commercial check ride? After all, the commercial exam only requires only 200 hours experience. You have much more flight experience than that, so have you been upgrading your skills during this time or just flitting about in the sky? Since you're not doing commercial flying you may not feel the need to acquire and maintain that level of skill. Well, why not? It will benefit your safety and that of your passengers.

Let's look at one of the maneuvers listed on the commercial pilot exam; the Lazy Eight.

So, why does a commercial pilot need to demonstrate skill at this maneuver? He is probably never going to do these in a Kingair, let alone in the 747 he has his career sights set on. Unlike training maneuvers such as turns around a point and rectangular patterns, the Lazy Eight has no direct application to day-to-day flying. However, the Lazy Eight is an excellent training maneuver for practicing control coordination, along with other things. I don't think that I need to make a case for the importance of control coordination, but I'll quickly do so by asking one simple question:

Q. What is the difference between a stall, and a stall/spin?

A. A stall /spin results from a stall encountered while the flight controls are un-coordinated.

My point being that it is easy to become complacent about our flying skills and to overlook the benefits of regular stick-and-rudder practice. Particularly if we are flying tri-gear airplanes (nothing inherently wrong with that), we can too easily "get by" without exercising good stick-and-rudder skills. We need to keep our skills honed to a high level to provide us with "skill to spare" for routine flying, and "skill to survive" in an emergency.

## VISUAL VERTIGO

I referred above to the “Rectangular Pattern” training maneuver. For practice, a course is selected in the countryside using roads or field section lines to describe a rectangular ground course. The object is for the student pilot to fly over this course at about 1000 ft. AGL, or typical traffic pattern altitude. The student learns to plan his turns so that he is aligned with the next course leg at the completion of each 90 degree turn. Add a wind to this practice, and it becomes more meaningful and more difficult for the beginner. Offset headings must be flown to maintain a flight line over the ground course, and adjustments must be made in the radius of turns to allow for the wind drift and the difference between airspeed and ground speed. The purpose of this exercise is obvious; it prepares the student to be able to fly an airport traffic pattern in a manner which result in flying a ground track which will position him for landing approach whether or not there is a wind..

Basic as the traffic pattern is, pilots still die while flying it. Why? Let’s look at a couple of traffic pattern illustrations to better understand one way this can happen.

Illustration 1.

This shows an ideal situation where there is no wind. We see the airplane tracking over the ground according to the heading of the airplane.

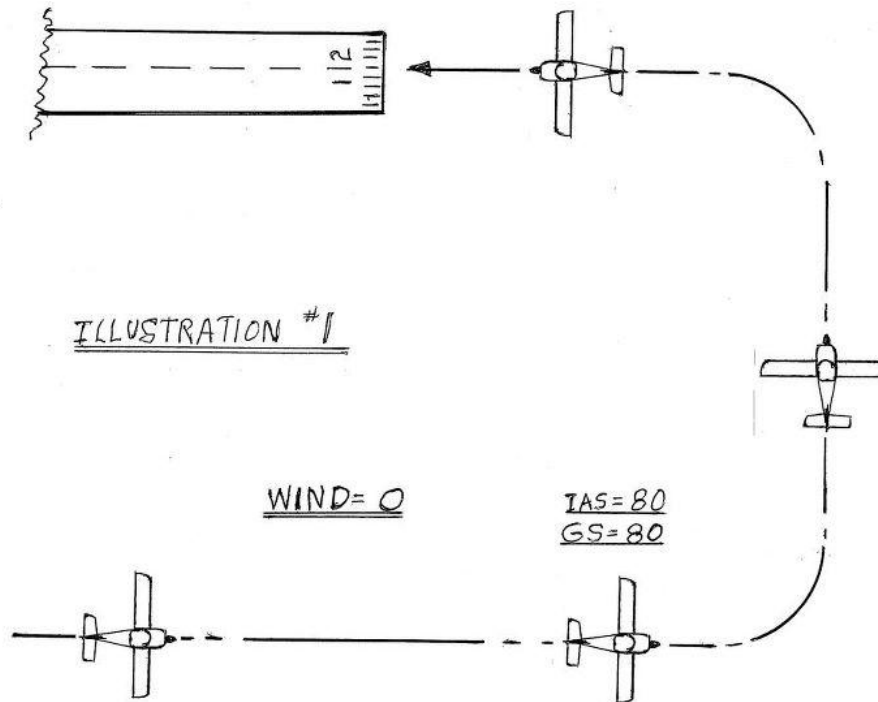

Illustration 2.

In this illustration we factor in a moderately strong wind at a 45 degree angle to the landing runway. This illustration shows a correctly flown pattern with the pilot having made heading corrections to compensate for wind drift. It also shows that he needed to begin his turns a bit sooner because of the higher ground speed and the fact that he needed to turn more than 90 degrees from one crabbed angle to another. He is able to maintain a desired ground track and arrive at the runway threshold at a desired altitude and airspeed. In reality, the airplane on final approach would probably not be crabbed into the wind as shown. A forward slip is the preferred *wind correction technique*, but too difficult to illustrate here.

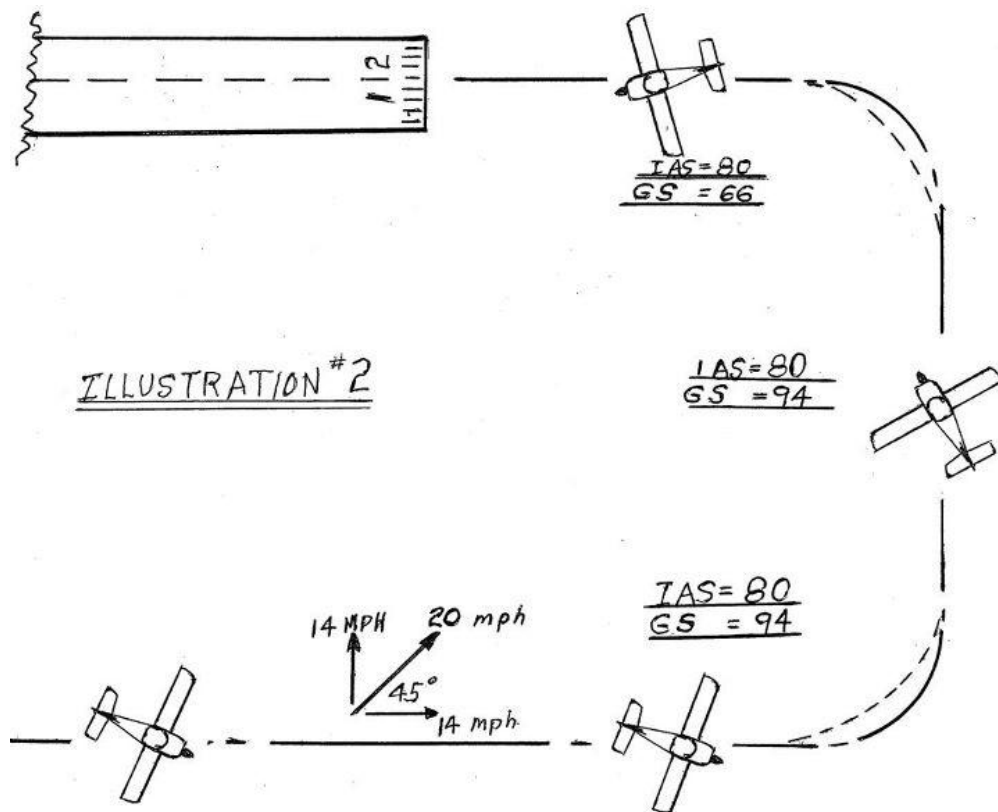
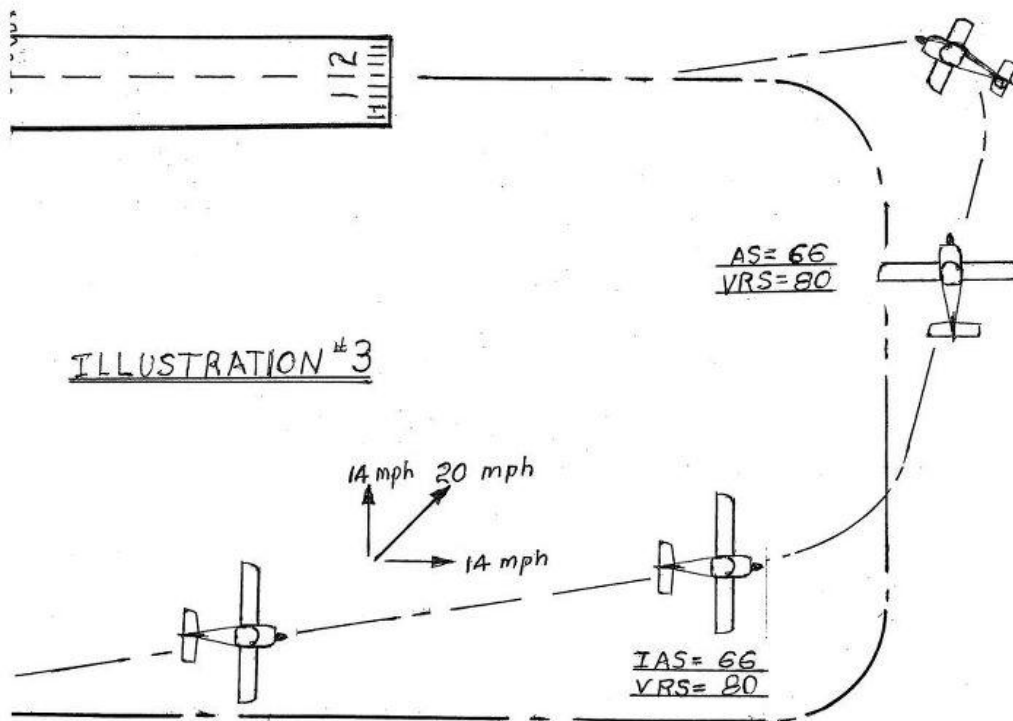

Illustration 3

Here we show a pattern flown without proper allowance and correction for wing drift. We have overlain the no-wind ground track for reference purposes. Please note the differences in IAS and GS (VRS).

One very, very important factor plays into this scenario. This is what I will call "Visual Reference Speed (VRS)". I like this term because it describes the speed that the pilot visually senses rather than the actual airspeed of his aircraft. We fly by "Visual" flight rules, and obviously we are more dependent on our visual sense than our other senses. We become accustomed to the visual rate and time cues we see while flying our regular airplane in standard traffic patterns. Illustration 3 assumes a pilot flying on the basis of conditioning acquired by flying no-wind traffic patterns.



First, the pilot made insufficient wind drift correction while flying the downwind leg, causing the plane to track closer to the runway. Also, the pilot relied on "Visual Reference Speed" cues for maintaining airspeed. He subconsciously reduced his airspeed (up-elevator, reduced power, or both) because the tailwind component causes the ground speed (visual reference speed) to be higher than normal. He sensed that he was flying too fast, but he really wasn't. Then, when making the turn to base leg, he leveled out on a

heading that again resulted in a drifting ground track, moving him further from the runway threshold.

The cross wind/tail wind causes the ground speed (visual reference speed) to be higher than the airspeed, thus a tendency to pull back on the control to slow down. As he descends nearer to the ground, the visual speed reference becomes more pronounced; more overpowering. Also, because the pilot had permitted his plane to be drifted off line on the downwind, the base leg has been shortened. Too soon it is time to initiate a turn to final approach.

Quite possibly, because of the tailwind component, the pilot will find that his turn rate is not progressing as fast as his angle of bank would indicate. The turn as established will result in an overshoot of runway alignment. So, he instinctively increases the bank angle and possibly adds a bit of inside rudder to “make it turn faster”. This scenario has all of the ingredients of a classic stall/spin turn-onto-final accident.

This hypothetical pilot was not engaging in overt reckless flying. He simply made a series of small errors which have culminated in a disaster.

Yes, the aircraft has an airspeed indicator, but I think that sometimes pilots subconsciously ignore the instrument’s indications because of the overpowering visual factor. It might be referred to as VFR vertigo, and in a sense it is. Basically, it is a disconnect between, or confusion of, our basic senses.

I mentioned the “Visual Reference Speed” cue as being the dominant sense but we also rely on audio and tactile cues. We are accustomed to the sound of the engine and the sound of the slipstream. We are accustomed to certain control pressures and feedback corresponding to certain speeds. When these senses are not in sync with each other, subliminal confusion results. This can lead to flawed judgments and reactions.

### **High Density Altitude.**

Operating at high density altitudes can also have similar effects. Because of the reduced air density there, aircraft will stall at higher true airspeeds. This means that, everything else being equal, higher true airspeeds and “visual” speeds are needed. When combined with winds as described above, the chances for errors in judgement increase.

### **Gusty Winds:**

Oh yes, in this crosswind scenario we must also consider that the atmosphere we are flying in is not stable. From second to second our airspeed can vary by 5 mph or more due to whims of the atmosphere (wind gusts, or, heaven forbid, “air pockets”.) The plane can be above stall speed at one moment and below stall speed a second or two later. Thus, the reason for maintaining a higher speed margin when flying approaches in windy conditions.

While this should all be second nature to experienced pilots, it doesn't hurt to periodically review and develop a subconscious awareness of it. Many pilots (and passengers) have died because of pilot error during the final minutes of an otherwise routine flight, so none of us should feel immune to error or complacent about our skills. Perhaps you have a different way of understanding of the concepts than I have explained here. That's fine. Then, perhaps this explanation might cause you to think through the procedure and get a better understanding of the reasons behind pitfalls of landing approaches.

### **“Dangerous Downwind Turns”**

Portions of the above dissertation should help explain the long-standing misconceptions that many have had about “dangerous downwind turns”. This is the belief that a wind from behind cancels the airflow over the wing and causes it to stall. This belief was held by pilots of early era, slow airplanes; airplanes which the pilot flew more by the seat-of-his-pants than by instrument reference.

In those early days, pilots may not have had the benefit of ground school training and knowledge of aerodynamic principles. Over the years pilots of certain classes of aircraft such as gyroplanes and ultra-lights have rediscovered this phenomenon. Since these are all slow aircraft, the tailwind effects and visual mis-cues are more pronounced. Many pilots of these aircraft may also have had limited training in aerodynamic theory.

I know that when flying a windy landing pattern in my long wing, less maneuverable sailplane, I need to be much more attentive to this phenomenon than when in a higher speed powered aircraft. I have experienced the sensory miscommunications described above, and find that it takes a strong conscious effort to overcome them.

Sometime when you are landing in a strong wind, particularly a strong cross wind, pay close attention and see if you can identify the phenomena I have described. Hopefully this will lead you to a better understanding of the forces at play, and help you becoming an even safer pilot.

Enough for now. Fly safely.

Van